



正基科技股份有限公司

SPECIFICATION

PRODUCT NAME : AP6684SDPR

REVISION : 0.3(WEB)

DATE : Jun. 15th , 2026

Customer APPROVED	
Company	
Representative Signature	

PREPARED	REVIEW			APPROVED	DCC ISSUE
	PM	QA	ET		





正基科技股份有限公司



AP6684SDPR

Data Sheet

Address:

6F., No. 23, Huanke 1st Rd., Zhubei City, Hsinchu County 302047,

Taiwan

<http://www.ampak.com.tw>



Revision

Revision	Date	Description	Revised By
0.1	2026/04/09	Preliminary Release	Jason
0.2	2026/05/22	Delete 802.11a MIMO RX	Sam
0.3	2026/06/15	Update General SPEC	Jason



Contents

1. Introduction	2
1.1 Overview	2
1.2 Product Features	3
2. General Specification	4
2.1 General Specification	4
2.2 DC Characteristics	4
2.2.1 Absolute Maximum Ratings	4
2.2.2 Recommended Operating Rating	5
3. Wi-Fi RF Specification	6
3.1 2.4GHz RF Specification	6
3.2 5GHz RF Specification	9
3.3 6GHz RF Specification	19
4. Bluetooth Specification	26
4.1 Bluetooth Specification	26
5. IEEE 802.15.4 Specification	28
5.1 IEEE 802.15.4 Specification	28
6. Pin Definition	29
6.1 Pin Outline	29
6.2 Pin Assignment	30
7. Dimensions	33
7.1 Module Dimensions	33
7.2 Recommended footprint	34
8. External clock reference	35
9. Host Interface Timing Diagram	36
9.1 Power-up Sequence Timing Diagram	36
9.2 PCIe Interface Description	38
9.3 PCM Interface Description	41
9.4 UART Interface Description	47
10. Recommended Reflow Profile	49
11. Package Information	50
11.1 Marking	50
11.2 Tape & Reel Date	50
11.3 Tape & Reel Packing	51

1. Introduction

1.1 Overview

The AMPAK Technology® AP6684SDPR is a Wi-Fi 7(2.4/5/6GHz) and Bluetooth functionalities module with seamless roaming capabilities and advance security, also it could interact with different vendors' 802.11a/b/g/n/ac/ax/be 2x2 Access Points with MIMO standard and can accomplish up to speed of 1200Mbps with dual stream in 802.11be to connect the wireless LAN. Furthermore AP6684SDPR included PCIE interface for Wi-Fi, UART/ PCM interface for Bluetooth.

In addition, this compact module is a total solution for a combination of Wi-Fi + Bluetooth technologies. The module is specifically developed for tablet, OTT box and portable devices.

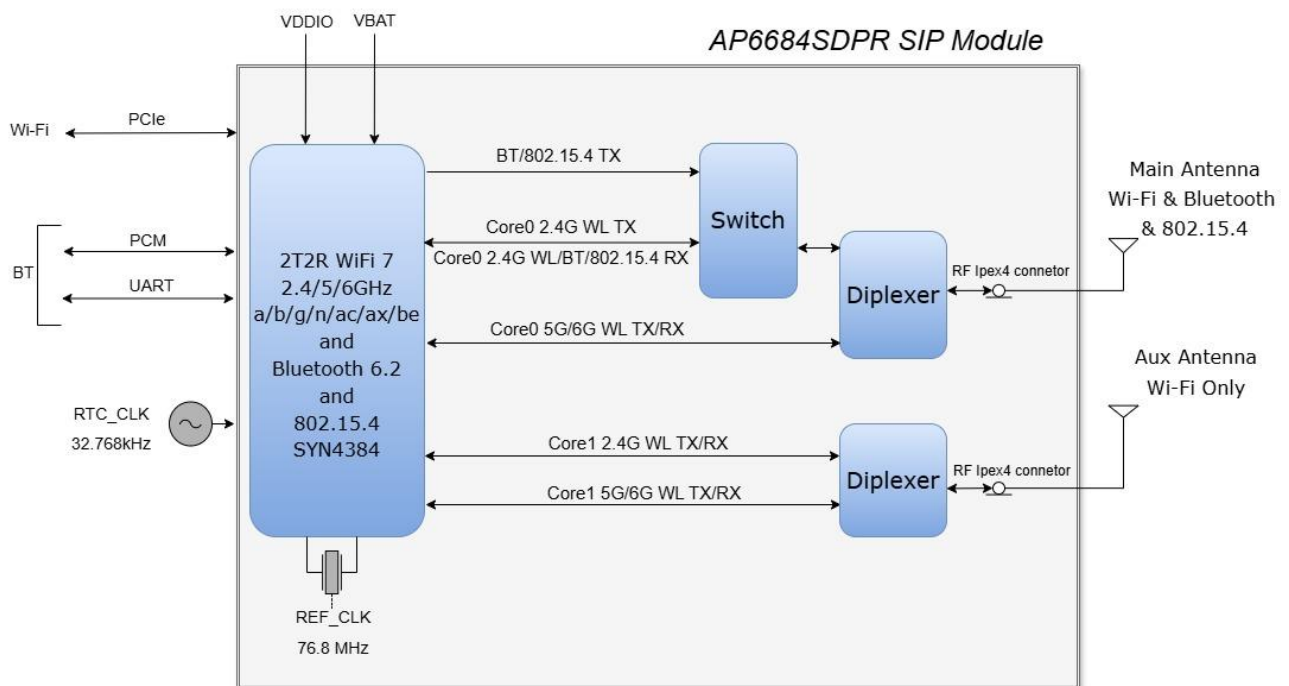

1.2 Product Features

IEEE 802.11 Key Features

- IEEE Wi-Fi 7 compliant.
- Lead Free design which is compliant with ROHS requirements.
- TX and RX low-density parity check (LDPC) support for improved range and power efficiency.
- Dual-stream spatial multiplexing up to 1200 Mbps data rate.
- 20/40/80 MHz channels for 5GHz and 6GHz radio, and 20MHz channels for 2.4GHz radio.
- Client MU-MIMO
- Supports PCI express revision 3.0 and power management running at Gen2 speeds.
- Support 1x1 2G + 1x1 5G/6G in Simultaneous Dual Band(SDB) mode
- Supported Partial RU(Resource Unit) in 802.11ax/be.
- Supported Multi RU in 802.11be.
- Supported Preamble Puncturing in 802.11be(BW80MHz).
- Supported non-HT(802.11a) preamble in 6GHz.

Bluetooth Key Features

- Bluetooth host digital interface:
 - HCI UART (up to 4 Mbps)
 - PCM for audio data
- Complies with Bluetooth Core Specification Version 6.2 with provisions for supporting future specifications. With Bluetooth Class 1 or Class2 transmitter operation.
- Supports extended synchronous connections (eSCO), for enhanced voice quality by allowing for retransmission of dropped packets.
- Adaptive frequency hopping (AFH) for reducing radio frequency interference.
A simplified block diagram of the module is depicted in the figure above.
- Bluetooth Core Specification Version 6.2, including the following support:
 - Low energy(LE) isochronous channels
 - LE power control
 - LE enhanced connection update
 - LE channel classification
 - LE audio(support Auracast BIS/CIS)
 - LE Long Range(LE-LR)
 - High Accuracy Distance Measurement (HAMD)/Channel Sounding

IEEE 802.15.4/Thread Key Feature

- Support IEEE 802.15.4/Thread that can act as Border Router.

2. General Specification

2.1 General Specification

Model Name	AP6684SDPR
Product Description	2T2R 802.11 a/b/g/n/ac/ax/be Wi-Fi 7 Bluetooth 6.2 / 802.15.4
Dimension	L x W : 16 x 12 (typical) mm , H : 2.15(max) mm
WiFi Interface	Support PCIe v3.0 compliant and runs at Gen2 speeds
Bluetooth Interface	UART / PCM
Operating temperature	-30°C to 85°C
Storage temperature	-40°C to 125°C
Humidity	Operating Humidity 10% to 95% Non-Condensing Storage Humidity 5% to 95% Non-Condensing

Note: The optimal RF performance specified in the data sheet, however, is guaranteed only -10 °C to +55 °C and 3.3V < VBAT < 4.2V without derating performance.

2.2 DC Characteristics

2.2.1 Absolute Maximum Ratings

Symbol	Description	Min.	Max.	Unit
VBAT	Input supply Voltage	-0.5	5.0	V
VDDIO	Digital/Bluetooth/ I/O Voltage	-0.5	2.07	V

Extreme caution must be exercised to prevent electrostatic discharge (ESD) damage.

Symbol	Condition	ESD Rating	Unit
ESD_HAND_HBM	Human body model contact discharge per JEDEC EID/JESD22-A114	1.5	Kv
ESD_HAND_CDM	Charged device model contact discharge per JEDEC EIA/JESD22-C101	250	V

2.2.2 Recommended Operating Rating

The module requires two power supplies: VBAT and VDDIO.

Voltage rails	Min.	Typ.	Max.	Unit
VBAT	3.3	3.6	4.2	V
VDDIO	1.62	1.8	1.98	V

VBAT current consumption 1200mA(Peak), when VBAT = 3.6V

The module requires two power supplies: other Digital I/O Pins.

For VDDIO=1.8V	Min.	Max.	Unit
VIH = Input high voltage	0.65 x VDDIO	NA	V
VIL = Input low voltage	NA	0.4 x VDDIO	V
VOH = Output high voltage @ 2mA	VDDIO – 0.4	NA	V
VOL = Output low voltage @ 2mA	NA	0.4	V

Programmable 2mA to 16mA drive strength. Default is 10mA.

3. Wi-Fi RF Specification

3.1 2.4GHz RF Specification

Conditions : VBAT=3.6V ; VDDIO=1.8V ; Temp :25°C

Feature	Description				
WLAN Standard	IEEE 802.11b/g/n/ax/be & Wi-Fi compliant				
Frequency Range	2.400 GHz ~ 2.4835 GHz (2.4GHz ISM Band)				
Number of Channels	2.4GHz : Ch1 ~ Ch13				
Modulation	802.11b : DQPSK 、 DBPSK 、 CCK 802.11 g/n : OFDM /64-QAM 、 16-QAM 、 QPSK 、 BPSK 802.11ax/be : OFDM /1024-QAM 、 256-QAM 、 64-QAM 、 16-QAM 、 QPSK 、 BPSK				
Resource Unit	Partial RU : BW20MHz : 26T 、 52T 、 106T 、 242T Multi RU : BW20MHz : 52T+26T 、 106T+26T				
Output Power(dBm) , tolerance ± 1.5 dB					
The transmit EVM quality & spectrum mask are compliant with IEEE 802.11 standard					
802.11b	1Mbps	2Mbps	5.5Mbps	11Mbps	
	18	18	18	18	
802.11g	6 、 9Mbps	12 、 18Mbps	24Mbps	36Mbps	48Mbps
	18	17.5	17.5	17	17
	54Mbps				
	17				
802.11n 20MHz	MCS0~2	MCS3	MCS4	MCS5	MCS6
	18	17.5	17.5	17	17
	MCS7				
	16				
802.11ac/ax 20MHz	MCS0~2/HE0~2	MCS3/HE3	MCS4/HE4	MCS5/HE5	MCS6/HE6
	18	17.5	17.5	17	17
	MCS7/HE7	MCS8/HE8	HE9	HE10	HE11
	16	15	14	14	14
802.11be 20MHz	HE0~2	HE3	HE4	HE5	HE6
	18	17.5	17.5	17	17
	HE7	HE8	HE9	HE10	HE11
	16	15	14	14	14

Note: The specifications of RF output power are subject to change to fulfill the safety regulation and requirements in end-user product.

Sensitivity, tolerance ± 2 Db
CCK modulation PER $\leq 8\%$ 、OFDM modulation PER $\leq 10\%$

802.11b	Data Rate	Spec.(dBm)		
	1Mbps	-97		
	2Mbps	-93		
	5.5Mbps	-91		
	11Mbps	-89		
802.11g SISO	Data Rate	Spec.(dBm)	Data Rate	Spec.(dBm)
	6Mbps	-93	24Mbps	-85
	9Mbps	-91	36Mbps	-81
	12Mbps	-90	48Mbps	-77
	18Mbps	-88	54Mbps	-75
802.11n_20MHz SISO	Data Rate	Spec.(dBm)	Data Rate	Spec.(dBm)
	MCS0	-93	MCS4	-81
	MCS1	-90	MCS5	-77
	MCS2	-87	MCS6	-75
	MCS3	-84	MCS7	-74
802.11n_20MHz MIMO	Data Rate	Spec.(dBm)	Data Rate	Spec.(dBm)
	MCS0	-95	MCS5	-79
	MCS1	-92	MCS6	-77
	MCS2	-89	MCS7	-76
	MCS3	-86	MCS8	-90
	MCS4	-83	MCS15	-71
802.11ac/ax_20MHz SISO	Data Rate	Spec.(dBm)	Data Rate	Spec.(dBm)
	MCS0/HE0	-93	MCS6/HE6	-77
	MCS1/HE1	-91	MCS7/HE7	-75
	MCS2/HE2	-89	MCS8/HE8	-71
	MCS3/HE3	-86	HE9	-69
	MCS4/HE4	-82	HE10	-66
	MCS5/HE5	-78	HE11	-63
802.11ac/ax_20MHz MIMO	Data Rate	Spec.(dBm)	Data Rate	Spec.(dBm)
	MCS0/HE0,NSS=1	-93	MCS8/HE8,NSS=1	-73
	MCS1/HE1,NSS=1	-93	HE9,NSS=1	-71
	MCS2/HE2,NSS=1	-91	HE10,NSS=1	-68
	MCS3/HE3,NSS=1	-88	HE11,NSS=1	-65

	MCS4/HE4,NSS=1	-85	MCS0/HE0,NSS=2	-91
	MCS5/HE5,NSS=1	-80	HE9,NSS=2	-67
	MCS6/HE6,NSS=1	-79	HE10,NSS=2	-64
	MCS7/HE7,NSS=1	-77	HE11,NSS=2	-61
802.11be_20MHz SISO	Data Rate	Spec.(dBm)	Data Rate	Spec.(dBm)
	HE0	-92	HE6	-76
	HE1	-90	HE7	-74
	HE2	-88	HE8	-70
	HE3	-85	HE9	-68
	HE4	-81	HE10	-65
	HE5	-77	HE11	-62
802.11be_20MHz MIMO	Data Rate	Spec.(dBm)	Data Rate	Spec.(dBm)
	HE0,NSS=1	-92	HE8,NSS=1	-72
	HE1,NSS=1	-92	HE9,NSS=1	-70
	HE2,NSS=1	-90	HE10,NSS=1	-67
	HE3,NSS=1	-87	HE11,NSS=1	-64
	HE4,NSS=1	-83	HE0,NSS=2	-90
	HE5,NSS=1	-79	HE9,NSS=2	-66
	HE6,NSS=1	-78	HE10,NSS=2	-63
	HE7,NSS=1	-76	HE11,NSS=2	-60
Maximum Input Level	802.11b : -10 dBm			
	802.11g/n/ax/be : -20 dBm			

3.2 5GHz RF Specification

Conditions : VBAT=3.6V ; VDDIO=1.8V ; Temp:25°C

Feature	Description				
WLAN Standard	IEEE 802.11a/n/ac/ax/be & Wi-Fi compliant				
Frequency Range	5.15~5.35GHz、5.47~5.725GHz、5.725~5.85GHz (5GHz UNII Band)				
Number of Channels	5.15~5.35GHz : Ch36 ~ Ch64 5.47~5.725GHz : Ch100 ~ Ch144 5.725~5.85GHz : Ch149 ~ Ch165				
Modulation	802.11a : OFDM /64-QAM、16-QAM、QPSK、BPSK 802.11n : OFDM /64-QAM、16-QAM、QPSK、BPSK 802.11ac : OFDM /256-QAM、OFDM /64-QAM、16-QAM、QPSK、BPSK 802.11ax/be : OFDM/ 1024-QAM、OFDM /256-QAM、OFDM /64-QAM、16-QAM、QPSK、BPSK				
Resource Unit	Partial RU : BW20MHz : 26T、52T、106T、242T BW40MHz : 26T、52T、106T、242T、484T BW80MHz : 26T、52T、106T、242T、484T、996T Multi RU : BW20MHz : 52T+26T、106T+26T BW40MHz : 52T+26T、106T+26T BW80MHz : 52T+26T、106T+26T、484T+242T Preamble Puncturing pattern: 1、2、4、8 (BW80MHz only)				
Output Power(dBm) , tolerance ± 2 dB					
The transmit EVM quality & spectrum mask are compliant with IEEE 802.11 standard					
802.11a	Frequency (MHz)	6~9Mbps	12~18Mbps	24Mbps	36Mbps
	5150~5350	15	15	15	15
	5470~5725	15	15	15	15
	5725~5845	15	15	15	15
	Frequency (MHz)	48Mbps	54Mbps		
	5150~5350	15	15		
	5470~5725	15	15		
	5725~5845	15	15		

802.11n 20MHz	Frequency (MHz)	MCS0~2	MCS3	MCS4	MCS5
	5150~5350	15	15	15	15
	5470~5725	15	15	15	15
	5725~5845	15	15	15	15
	Frequency (MHz)	MCS6	MCS7		
	5150~5350	15	14		
	5470~5725	15	14		
	5725~5845	15	14		
802.11n 40MHz	Frequency (MHz)	MCS0~2	MCS3	MCS4	MCS5
	5150~5350	15	15	15	15
	5470~5725	15	15	15	15
	5725~5845	15	15	15	15
	Frequency (MHz)	MCS6	MCS7		
	5150~5350	14	14		
	5470~5725	14	14		
	5725~5845	14	14		
802.11ac 20MHz	Frequency (MHz)	MCS0~2	MCS3	MCS4	MCS5
	5150~5350	15	15	15	15
	5470~5725	15	15	15	15
	5725~5845	15	15	15	15
	Frequency (MHz)	MCS6	MCS7	MCS8	
	5150~5350	15	14	12	
	5470~5725	15	14	12	
	5725~5845	15	14	12	
802.11ac 40MHz	Frequency (MHz)	MCS0~2	MCS3	MCS4	MCS5
	5150~5350	15	15	15	15
	5470~5725	15	15	15	15
	5725~5845	15	15	15	15
	Frequency (MHz)	MCS6	MCS7	MCS8	MCS9
	5150~5350	14	14	12	10
	5470~5725	14	14	12	10
	5725~5845	14	14	12	10

802.11ac 80MHz	Frequency (MHz)	MCS0~2	MCS3	MCS4	MCS5
	5150~5350	15	15	14.5	14.5
	5470~5725	15	15	14.5	14.5
	5725~5845	15	15	14.5	14.5
	Frequency (MHz)	MCS6	MCS7	MCS8	MCS9
	5150~5350	14	14	10	10
	5470~5725	14	14	10	10
	5725~5845	14	14	10	10
802.11ax 20MHz	Frequency (MHz)	HE0~2	HE3	HE4	HE5
	5150~5350	15	15	15	15
	5470~5725	15	15	15	15
	5725~5845	15	15	15	15
	Frequency (MHz)	HE6	HE7	HE8	HE9
	5150~5350	14.5	14.5	12	12
	5470~5725	14.5	14.5	12	12
	5725~5845	14.5	14.5	12	12
	Frequency (MHz)	HE10	HE11		
	5150~5350	10	10		
	5470~5725	10	10		
	5725~5845	10	10		
802.11ax 40MHz	Frequency (MHz)	HE0~2	HE3	HE4	HE5
	5150~5350	15	15	15	15
	5470~5725	15	15	15	15
	5725~5845	15	15	15	15
	Frequency (MHz)	HE6	HE7	HE8	HE9
	5150~5350	14.5	14.5	12	10
	5470~5725	14.5	14.5	12	10
	5725~5845	14.5	14.5	12	10
	Frequency (MHz)	HE10	HE11		
	5150~5350	8	8		
	5470~5725	8	8		
	5725~5845	8	8		

802.11ax 80MHz	Frequency (MHz)	HE0~2	HE3	HE4	HE5
	5150~5350	15	15	14.5	14.5
	5470~5725	15	15	14.5	14.5
	5725~5845	15	15	14.5	14.5
	Frequency (MHz)	HE6	HE7	HE8	HE9
	5150~5350	14	14	10	10
	5470~5725	14	14	10	10
	5725~5845	14	14	10	10
	Frequency (MHz)	HE10	HE11		
	5150~5350	8	8		
	5470~5725	8	8		
	5725~5845	8	8		
802.11be 20MHz	Frequency (MHz)	HE0~2	HE3	HE4	HE5
	5150~5350	15	15	15	15
	5470~5725	15	15	15	15
	5725~5845	15	15	15	15
	Frequency (MHz)	HE6	HE7	HE8	HE9
	5150~5350	14.5	14.5	12	12
	5470~5725	14.5	14.5	12	12
	5725~5845	14.5	14.5	12	12
	Frequency (MHz)	HE10	HE11		
	5150~5350	10	10		
	5470~5725	10	10		
	5725~5845	10	10		
802.11be 40MHz	Frequency (MHz)	HE0~2	HE3	HE4	HE5
	5150~5350	15	15	15	15
	5470~5725	15	15	15	15
	5725~5845	15	15	15	15
	Frequency (MHz)	HE6	HE7	HE8	HE9
	5150~5350	14.5	14.5	12	10
	5470~5725	14.5	14.5	12	10
	5725~5845	14.5	14.5	12	10
	Frequency (MHz)	HE10	HE11		
	5150~5350	8	8		
	5470~5725	8	8		
	5725~5845	8	8		

802.11be 80MHz	Frequency (MHz)	HE0~2	HE3	HE4	HE5
	5150~5350	15	15	14.5	14.5
	5470~5725	15	15	14.5	14.5
	5725~5845	15	15	14.5	14.5
	Frequency (MHz)	HE6	HE7	HE8	HE9
	5150~5350	14	14	10	10
	5470~5725	14	14	10	10
	5725~5845	14	14	10	10
	Frequency (MHz)	HE10	HE11		
	5150~5350	8	8		
	5470~5725	8	8		
	5725~5845	8	8		

Note: The specifications of RF output power are subject to change to fulfill the safety regulation and requirements in end-user product.

Sensitivity, tolerance ± 2 dB , OFDM modulation PER $\leq 10\%$				
802.11a SISO	Data Rate	Spec.(dBm)	Data Rate	Spec.(dBm)
	6Mbps	-90	24Mbps	-82
	9Mbps	-88	36Mbps	-79
	12Mbps	-87	48Mbps	-74
	18Mbps	-85	54Mbps	-73
802.11n_20MHz SISO	Data Rate	Spec.(dBm)	Data Rate	Spec.(dBm)
	MCS0	-90	MCS4	-78
	MCS1	-87	MCS5	-75
	MCS2	-85	MCS6	-73
	MCS3	-82	MCS7	-71
802.11n_20MHz MIMO	Data Rate	Spec.(dBm)	Data Rate	Spec.(dBm)
	MCS0	-92	MCS5	-77
	MCS1	-89	MCS6	-75
	MCS2	-87	MCS7	-73
	MCS3	-84	MCS8	-88
	MCS4	-80	MCS15	-69
802.11n_40MHz SISO	Data Rate	Spec.(dBm)	Data Rate	Spec.(dBm)
	MCS0	-87	MCS4	-76
	MCS1	-85	MCS5	-71
	MCS2	-82	MCS6	-70
	MCS3	-79	MCS7	-68
802.11n_40MHz MIMO	Data Rate	Spec.(dBm)	Data Rate	Spec.(dBm)
	MCS0	-89	MCS5	-73
	MCS1	-87	MCS6	-72
	MCS2	-84	MCS7	-70
	MCS3	-81	MCS8	-85
	MCS4	-78	MCS15	-66

802.11ac_20MHz SISO	Data Rate	Spec.(dBm)	Data Rate	Spec.(dBm)
	MCS0	-90	MCS5	-74
	MCS1	-87	MCS6	-72
	MCS2	-85	MCS7	-71
	MCS3	-82	MCS8	-67
	MCS4	-78		
802.11ac_20MHz MIMO	Data Rate	Spec.(dBm)	Data Rate	Spec.(dBm)
	MCS0,NSS=1	-90	MCS6,NSS=1	-74
	MCS1,NSS=1	-89	MCS7,NSS=1	-73
	MCS2,NSS=1	-87	MCS8,NSS=1	-69
	MCS3,NSS=1	-84	MCS0,NSS=2	-88
	MCS4,NSS=1	-80	MCS8,NSS=2	-65
	MCS5,NSS=1	-76		
802.11ac_40MHz SISO	Data Rate	Spec.(dBm)	Data Rate	Spec.(dBm)
	MCS0	-87	MCS5	-72
	MCS1	-84	MCS6	-70
	MCS2	-82	MCS7	-68
	MCS3	-79	MCS8	-64
	MCS4	-76	MCS9	-63
802.11ac_40MHz MIMO	Data Rate	Spec.(dBm)	Data Rate	Spec.(dBm)
	MCS0,NSS=1	-88	MCS6,NSS=1	-72
	MCS1,NSS=1	-86	MCS7,NSS=1	-70
	MCS2,NSS=1	-84	MCS8,NSS=1	-66
	MCS3,NSS=1	-81	MCS9,NSS=1	-65
	MCS4,NSS=1	-78	MCS0,NSS=2	-85
	MCS5,NSS=1	-74	MCS9,NSS=2	-61
802.11ac_80MHz SISO	Data Rate	Spec.(dBm)	Data Rate	Spec.(dBm)
	MCS0	-84	MCS5	-68
	MCS1	-81	MCS6	-67
	MCS2	-79	MCS7	-65
	MCS3	-75	MCS8	-62
	MCS4	-72	MCS9	-59

802.11ac_80MHz MIMO	Data Rate	Spec.(dBm)	Data Rate	Spec.(dBm)
	MCS0,NSS=1	-85	MCS6,NSS=1	-69
	MCS1,NSS=1	-83	MCS7,NSS=1	-67
	MCS2,NSS=1	-81	MCS8,NSS=1	-64
	MCS3,NSS=1	-77	MCS9,NSS=1	-61
	MCS4,NSS=1	-74	MCS0,NSS=2	-82
	MCS5,NSS=1	-70	MCS9,NSS=2	-57
802.11ax_20MHz SISO	Data Rate	Spec.(dBm)	Data Rate	Spec.(dBm)
	HE0	-90	HE6	-73
	HE1	-88	HE7	-70
	HE2	-86	HE8	-68
	HE3	-83	HE9	-64
	HE4	-79	HE10	-59
	HE5	-75	HE11	-57
802.11ax_20MHz MIMO	Data Rate	Spec.(dBm)	Data Rate	Spec.(dBm)
	HE0,NSS=1	-90	HE8,NSS=1	-70
	HE1,NSS=1	-90	HE9,NSS=1	-66
	HE2,NSS=1	-88	HE10,NSS=1	-61
	HE3,NSS=1	-85	HE11,NSS=1	-59
	HE4,NSS=1	-81	HE0,NSS=2	-88
	HE5,NSS=1	-77	HE9,NSS=2	-62
	HE6,NSS=1	-75	HE10,NSS=2	-57
	HE7,NSS=1	-72	HE11,NSS=2	-55
802.11ax_40MHz SISO	Data Rate	Spec.(dBm)	Data Rate	Spec.(dBm)
	HE0	-88	HE6	-70
	HE1	-86	HE7	-68
	HE2	-83	HE8	-65
	HE3	-80	HE9	-63
	HE4	-76	HE10	-58
802.11ax_40MHz MIMO	Data Rate	Spec.(dBm)	Data Rate	Spec.(dBm)
	HE0,NSS=1	-89	HE8,NSS=1	-67
	HE1,NSS=1	-88	HE9,NSS=1	-65
	HE2,NSS=1	-85	HE10,NSS=1	-60
	HE3,NSS=1	-82	HE11,NSS=1	-57
	HE4,NSS=1	-78	HE0,NSS=2	-86
HE5,NSS=1	-74	HE9,NSS=2	-61	

	HE6,NSS=1	-72	HE10,NSS=2	-56
	HE7,NSS=1	-70	HE11,NSS=2	-53
802.11ax_80MHz SISO	Data Rate	Spec.(dBm)	Data Rate	Spec.(dBm)
	HE0	-85	HE6	-67
	HE1	-82	HE7	-65
	HE2	-79	HE8	-62
	HE3	-76	HE9	-61
	HE4	-73	HE10	-55
	HE5	-68	HE11	-51
	802.11ax_80MHz MIMO	Data Rate	Spec.(dBm)	Data Rate
HE0,NSS=1		-86	HE8,NSS=1	-64
HE1,NSS=1		-84	HE9,NSS=1	-63
HE2,NSS=1		-81	HE10,NSS=1	-57
HE3,NSS=1		-78	HE11,NSS=1	-53
HE4,NSS=1		-75	HE0,NSS=2	-83
HE5,NSS=1		-70	HE9,NSS=2	-59
HE6,NSS=1		-69	HE10,NSS=2	-53
HE7,NSS=1		-67	HE11,NSS=2	-49
802.11be_20MHz SISO	Data Rate	Spec.(dBm)	Data Rate	Spec.(dBm)
	HE0	-90	HE6	-73
	HE1	-88	HE7	-70
	HE2	-86	HE8	-68
	HE3	-83	HE9	-64
	HE4	-79	HE10	-59
	HE5	-75	HE11	-57
802.11be_20MHz MIMO	Data Rate	Spec.(dBm)	Data Rate	Spec.(dBm)
	HE0,NSS=1	-90	HE8,NSS=1	-70
	HE1,NSS=1	-90	HE9,NSS=1	-66
	HE2,NSS=1	-88	HE10,NSS=1	-61
	HE3,NSS=1	-85	HE11,NSS=1	-59
	HE4,NSS=1	-81	HE0,NSS=2	-88
	HE5,NSS=1	-77	HE9,NSS=2	-62
	HE6,NSS=1	-75	HE10,NSS=2	-57
	HE7,NSS=1	-72	HE11,NSS=2	-55

802.11be_40MHz SISO	Data Rate	Spec.(dBm)	Data Rate	Spec.(dBm)
	HE0	-88	HE6	-70
	HE1	-86	HE7	-68
	HE2	-83	HE8	-65
	HE3	-80	HE9	-63
	HE4	-76	HE10	-58
	HE5	-72	HE11	-55
802.11be_40MHz MIMO	Data Rate	Spec.(dBm)	Data Rate	Spec.(dBm)
	HE0,NSS=1	-89	HE8,NSS=1	-67
	HE1,NSS=1	-88	HE9,NSS=1	-65
	HE2,NSS=1	-85	HE10,NSS=1	-60
	HE3,NSS=1	-82	HE11,NSS=1	-57
	HE4,NSS=1	-78	HE0,NSS=2	-86
	HE5,NSS=1	-74	HE9,NSS=2	-61
	HE6,NSS=1	-72	HE10,NSS=2	-56
	HE7,NSS=1	-70	HE11,NSS=2	-53
802.11be_80MHz SISO	Data Rate	Spec.(dBm)	Data Rate	Spec.(dBm)
	HE0	-85	HE6	-67
	HE1	-82	HE7	-65
	HE2	-79	HE8	-62
	HE3	-76	HE9	-61
	HE4	-73	HE10	-55
802.11be_80MHz MIMO	Data Rate	Spec.(dBm)	Data Rate	Spec.(dBm)
	HE0,NSS=1	-86	HE8,NSS=1	-64
	HE1,NSS=1	-84	HE9,NSS=1	-63
	HE2,NSS=1	-81	HE10,NSS=1	-57
	HE3,NSS=1	-78	HE11,NSS=1	-53
	HE4,NSS=1	-75	HE0,NSS=2	-83
	HE5,NSS=1	-70	HE9,NSS=2	-59
	HE6,NSS=1	-69	HE10,NSS=2	-53
HE7,NSS=1	-67	HE11,NSS=2	-49	
Maximum Input Level	802.11a/n/ac/ax/be : -30 dBm			

3.3 6GHz RF Specification

Conditions : VBAT=3.6V ; VDDIO=1.8V ; Temp:25°C

Feature	Description
WLAN Standard	IEEE 802.11ax/be Non-HT(802.11a) preamble for ack/beacon
Frequency Range	5.925 ~ 7.125GHz
Number of Channels	5955~6415MHz : 6G1 ~ 6G93 、 6435~6515MHz : 6G97 ~ 6G113 6535~6855MHz : 6G117 ~ 6G181 、 6875~7115MHz : 6G185 ~ 6G233
Modulation	802.11ax/be : OFDMA /1024-QAM 、 256-QAM 、 64-QAM 、 16-QAM 、 QPSK 、 BPSK
Resource Unit	Partial RU : BW20MHz : 26T 、 52T 、 106T 、 242T BW40MHz : 26T 、 52T 、 106T 、 242T 、 484T BW80MHz : 26T 、 52T 、 106T 、 242T 、 484T 、 996T Multi RU : BW20MHz : 52T+26T 、 106T+26T BW40MHz : 52T+26T 、 106T+26T BW80MHz : 52T+26T 、 106T+26T 、 484T+242T Preamble Puncturing pattern: 1 、 2 、 4 、 8 (BW80MHz only)

Output Power(dBm) , tolerance ± 2 dB

The transmit EVM quality & spectrum mask are compliant with IEEE 802.11 standard

802.11ax 20MHz	Frequency (MHz)	HE0~2	HE3	HE4	HE5
	5955~6415	14	14	13.5	13.5
	6435~6515	14	14	13.5	13.5
	6535~6855	14	14	13.5	13.5
	6875~7115	14	14	13.5	13.5
	Frequency (MHz)	HE6	HE7	HE8	HE9
	5955~6415	13.5	12.5	10.5	10.5
	6435~6515	13.5	12.5	10.5	10.5
	6535~6855	13.5	12.5	10.5	10.5
	6875~7115	13.5	12.5	10.5	10.5
	Frequency (MHz)	HE10	HE11		
	5955~6415	8.5	8.5		
	6435~6515	8.5	8.5		
	6535~6855	8.5	8.5		
	6875~7115	8.5	8.5		

802.11ax 40MHz	Frequency (MHz)	HE0~2	HE3	HE4	HE5
	5955~6415	14	14	13	13
	6435~6515	14	14	13	13
	6535~6855	14	14	13	13
	6875~7115	14	14	13	13
	Frequency (MHz)	HE6	HE7	HE8	HE9
	5955~6415	12.5	12.5	11	8
	6435~6515	12.5	12.5	11	8
	6535~6855	12.5	12.5	11	8
	6875~7115	12.5	12.5	11	8
	Frequency (MHz)	HE10	HE11		
	5955~6415	7	7		
	6435~6515	7	7		
	6535~6855	7	7		
	6875~7115	7	7		
802.11ax 80MHz	Frequency (MHz)	HE0~2	HE3	HE4	HE5
	5955~6415	14	14	13	13
	6435~6515	14	14	13	13
	6535~6855	14	14	13	13
	6875~7115	14	14	13	13
	Frequency (MHz)	HE6	HE7	HE8	HE9
	5955~6415	12.5	12.5	8	8
	6435~6515	12.5	12.5	8	8
	6535~6855	12.5	12.5	8	8
	6875~7115	12.5	12.5	8	8
	Frequency (MHz)	HE10	HE11		
	5955~6415	7	7		
	6435~6515	7	7		
	6535~6855	7	7		
	6875~7115	7	7		

802.11be 20MHz	Frequency (MHz)	HE0~2	HE3	HE4	HE5
	5955~6415	14	14	13.5	13.5
	6435~6515	14	14	13.5	13.5
	6535~6855	14	14	13.5	13.5
	6875~7115	14	14	13.5	13.5
	Frequency (MHz)	HE6	HE7	HE8	HE9
	5955~6415	13.5	12.5	10.5	10.5
	6435~6515	13.5	12.5	10.5	10.5
	6535~6855	13.5	12.5	10.5	10.5
	6875~7115	13.5	12.5	10.5	10.5
	Frequency (MHz)	HE10	HE11		
	5955~6415	8.5	8.5		
	6435~6515	8.5	8.5		
	6535~6855	8.5	8.5		
6875~7115	8.5	8.5			
802.11be 40MHz	Frequency (MHz)	HE0~2	HE3	HE4	HE5
	5955~6415	14	14	13	13
	6435~6515	14	14	13	13
	6535~6855	14	14	13	13
	6875~7115	14	14	13	13
	Frequency (MHz)	HE6	HE7	HE8	HE9
	5955~6415	12.5	12.5	11	8
	6435~6515	12.5	12.5	11	8
	6535~6855	12.5	12.5	11	8
	6875~7115	12.5	12.5	11	8
	Frequency (MHz)	HE10	HE11		
	5955~6415	7	7		
	6435~6515	7	7		
	6535~6855	7	7		
6875~7115	7	7			

802.11be 80MHz	Frequency (MHz)	HE0~2	HE3	HE4	HE5
	5955~6415	14	14	13	13
	6435~6515	14	14	13	13
	6535~6855	14	14	13	13
	6875~7115	14	14	13	13
	Frequency (MHz)	HE6	HE7	HE8	HE9
	5955~6415	12.5	12.5	8	8
	6435~6515	12.5	12.5	8	8
	6535~6855	12.5	12.5	8	8
	6875~7115	12.5	12.5	8	8
	Frequency (MHz)	HE10	HE11		
	5955~6415	7	7		
	6435~6515	7	7		
	6535~6855	7	7		
6875~7115	7	7			

Note: The specifications of RF output power are subject to change to fulfill the safety regulation and requirements in end-user product.

Sensitivity, tolerance ± 2 dB, OFDM modulation PER $\leq 10\%$

802.11ax_20MHz SISO	Data Rate	Spec.(dBm)	Data Rate	Spec.(dBm)
	HE0	-88	HE6	-71
	HE1	-86	HE7	-68
	HE2	-84	HE8	-66
	HE3	-81	HE9	-62
	HE4	-77	HE10	-57
	HE5	-73	HE11	-55
802.11ax_20MHz MIMO	Data Rate	Spec.(dBm)	Data Rate	Spec.(dBm)
	HE0,NSS=1	-89	HE8,NSS=1	-68
	HE1,NSS=1	-88	HE9,NSS=1	-64
	HE2,NSS=1	-86	HE10,NSS=1	-59
	HE3,NSS=1	-83	HE11,NSS=1	-57
	HE4,NSS=1	-79	HE0,NSS=2	-86
	HE5,NSS=1	-75	HE9,NSS=2	-60
	HE6,NSS=1	-73	HE10,NSS=2	-55
	HE7,NSS=1	-70	HE11,NSS=2	-53

802.11ax_40MHz SISO	Data Rate	Spec.(dBm)	Data Rate	Spec.(dBm)
	HE0	-86	HE6	-68
	HE1	-84	HE7	-66
	HE2	-81	HE8	-63
	HE3	-78	HE9	-61
	HE4	-74	HE10	-56
	HE5	-70	HE11	-53
802.11ax_40MHz MIMO	Data Rate	Spec.(dBm)	Data Rate	Spec.(dBm)
	HE0,NSS=1	-87	HE8,NSS=1	-65
	HE1,NSS=1	-86	HE9,NSS=1	-63
	HE2,NSS=1	-83	HE10,NSS=1	-58
	HE3,NSS=1	-80	HE11,NSS=1	-55
	HE4,NSS=1	-76	HE0,NSS=2	-84
	HE5,NSS=1	-72	HE9,NSS=2	-59
	HE6,NSS=1	-70	HE10,NSS=2	-54
	HE7,NSS=1	-68	HE11,NSS=2	-51
802.11ax_80MHz SISO	Data Rate	Spec.(dBm)	Data Rate	Spec.(dBm)
	HE0	-83	HE6	-65
	HE1	-80	HE7	-63
	HE2	-77	HE8	-60
	HE3	-74	HE9	-59
	HE4	-71	HE10	-53
	HE5	-66	HE11	-49
802.11ax_80MHz MIMO	Data Rate	Spec.(dBm)	Data Rate	Spec.(dBm)
	HE0,NSS=1	-84	HE8,NSS=1	-62
	HE1,NSS=1	-82	HE9,NSS=1	-61
	HE2,NSS=1	-79	HE10,NSS=1	-55
	HE3,NSS=1	-76	HE11,NSS=1	-51
	HE4,NSS=1	-73	HE0,NSS=2	-81
	HE5,NSS=1	-68	HE9,NSS=2	-57
	HE6,NSS=1	-67	HE10,NSS=2	-51
	HE7,NSS=1	-65	HE11,NSS=2	-47

802.11be_20MHz SISO	Data Rate	Spec.(dBm)	Data Rate	Spec.(dBm)
	HE0	-88	HE6	-71
	HE1	-86	HE7	-68
	HE2	-84	HE8	-66
	HE3	-81	HE9	-62
	HE4	-77	HE10	-57
	HE5	-73	HE11	-55
802.11be_20MHz MIMO	Data Rate	Spec.(dBm)	Data Rate	Spec.(dBm)
	HE0,NSS=1	-89	HE8,NSS=1	-68
	HE1,NSS=1	-88	HE9,NSS=1	-64
	HE2,NSS=1	-86	HE10,NSS=1	-59
	HE3,NSS=1	-83	HE11,NSS=1	-57
	HE4,NSS=1	-79	HE0,NSS=2	-86
	HE5,NSS=1	-75	HE9,NSS=2	-60
	HE6,NSS=1	-73	HE10,NSS=2	-55
	HE7,NSS=1	-70	HE11,NSS=2	-53
802.11be_40MHz SISO	Data Rate	Spec.(dBm)	Data Rate	Spec.(dBm)
	HE0	-86	HE6	-68
	HE1	-84	HE7	-66
	HE2	-81	HE8	-63
	HE3	-78	HE9	-61
	HE4	-74	HE10	-56
	HE5	-70	HE11	-53
802.11be_40MHz MIMO	Data Rate	Spec.(dBm)	Data Rate	Spec.(dBm)
	HE0,NSS=1	-87	HE8,NSS=1	-65
	HE1,NSS=1	-86	HE9,NSS=1	-63
	HE2,NSS=1	-83	HE10,NSS=1	-58
	HE3,NSS=1	-80	HE11,NSS=1	-55
	HE4,NSS=1	-76	HE0,NSS=2	-84
	HE5,NSS=1	-72	HE9,NSS=2	-59
	HE6,NSS=1	-70	HE10,NSS=2	-54
	HE7,NSS=1	-68	HE11,NSS=2	-51

802.11be_80MHz SISO	Data Rate	Spec.(dBm)	Data Rate	Spec.(dBm)
	HE0	-83	HE6	-65
	HE1	-80	HE7	-63
	HE2	-77	HE8	-60
	HE3	-74	HE9	-59
	HE4	-71	HE10	-53
	HE5	-66	HE11	-49
802.11be_80MHz MIMO	Data Rate	Spec.(dBm)	Data Rate	Spec.(dBm)
	HE0,NSS=1	-84	HE8,NSS=1	-62
	HE1,NSS=1	-82	HE9,NSS=1	-61
	HE2,NSS=1	-79	HE10,NSS=1	-55
	HE3,NSS=1	-76	HE11,NSS=1	-51
	HE4,NSS=1	-73	HE0,NSS=2	-81
	HE5,NSS=1	-68	HE9,NSS=2	-57
	HE6,NSS=1	-67	HE10,NSS=2	-51
	HE7,NSS=1	-65	HE11,NSS=2	-47
Maximum Input Level	802.11ax/be : -30dBm			

4. Bluetooth Specification

4.1 Bluetooth Specification

Conditions : VBAT=3.6V ; VDDIO=1.8V ; Temp:25°C

Feature	Description
General Specification	
Bluetooth Standard	BDR、EDR(2Mbps & 3Mbps)、LE(1/2Mbps)、LELR(128/512Kbps)
Host Interface	UART
Frequency Band	2402 MHz ~ 2480 MHz
Number of Channels	79 channels for classic、40 channels for BLE
Modulation	GFSK, $\pi/4$ -DQPSK, 8DPSK
RF Specification	
Output Power, tolerance ± 2 dB	
	CL1 (dBm)
BDR Output Power	6
EDR Output Power	6
BLE Output Power	6
Sensitivity, tolerance ± 2 dB	
Sensitivity @ BER=0.1% for GFSK (1Mbps)	-88 dBm
Sensitivity @ BER=0.01% for $\pi/4$ -DQPSK (2Mbps)	-91 dBm
Sensitivity @ BER=0.01% for 8DPSK (3Mbps)	-85 dBm
Sensitivity @ PER=30.8% for LE (1Mbps)	-90 dBm
Sensitivity @ PER=30.8% for 2LE (2Mbps)	-91 dBm
Sensitivity @ PER=30.8% for LELR (125Kbps)	-103 dBm
Sensitivity @ PER=30.8% for LELR (500Kbps)	-97 dBm

Maximum Input Level	GFSK (1Mbps):-20dBm
	$\pi/4$ -DQPSK (2Mbps) :-20dBm
	8DPSK (3Mbps) :-20dBm

Note* : The Bluetooth output power is able to be configured by firmware (hcd file).

5. IEEE 802.15.4 Specification

5.1 IEEE 802.15.4 Specification

Conditions : VBAT=3.6V ; VDDIO=1.8V ; Temp:25°C

Feature	Description
General Specification	
Standard	IEEE 802.15.4
Host Interface	UART
Frequency Band	2405 MHz ~ 2480 MHz
Number of Channels	16 channels(channel 11~channel 26)
Channel list	2405(ch11) 、 2410(ch12)... 、 2480(ch26)
Modulation	OQPSK(250kbps)
RF Specification	
Output Power , tolerance ± 2 dB	
OQPSK Output Power*	6 dBm
Sensitivity, tolerance ± 2 dB	
Sensitivity @ PER=1% for 250kbps OQPSK	-97 dBm

Note* : The output power is able to be configured by firmware (hcd file).

6. Pin Definition

6.1 Pin Outline

PIN OUTLINE <TOP VIEW>

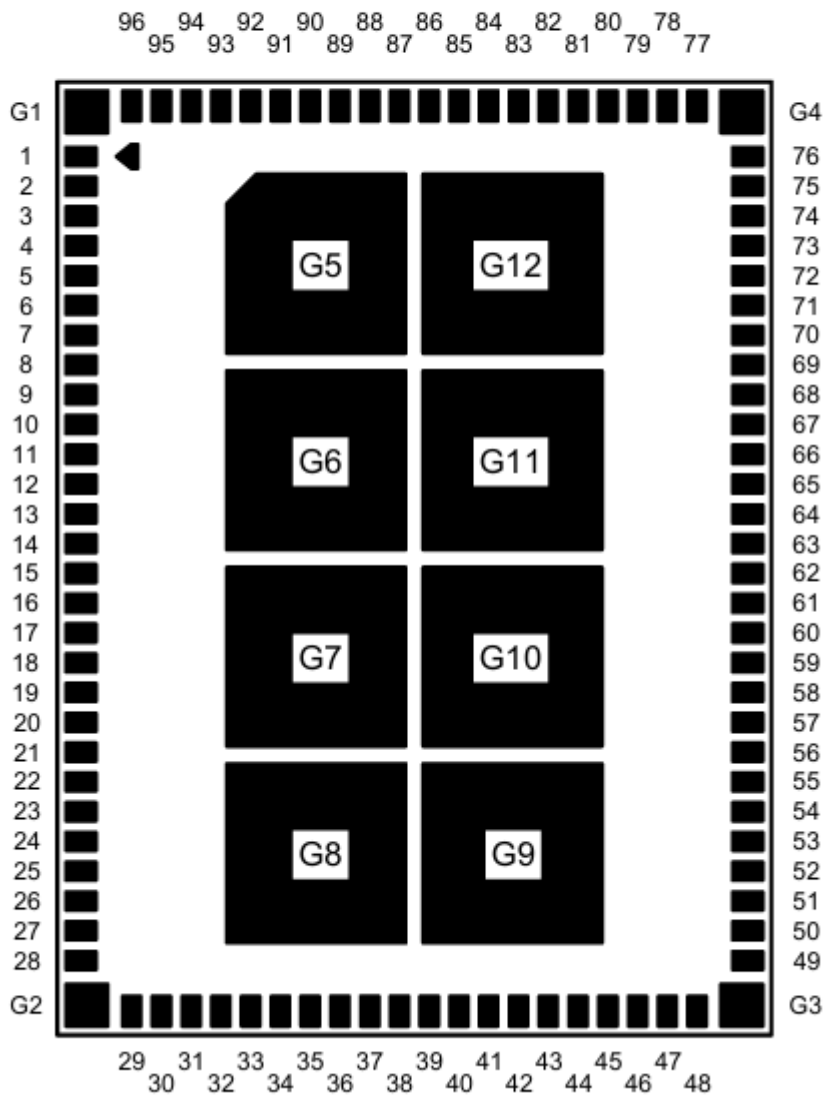

6.2 Pin Assignment

NO	Name	Type	Description
1	GND	—	Ground connections
2	GND	—	Ground connections
3	GND	—	Ground connections
4	GND	—	Ground connections
5	GND	—	Ground connections
6	NC	—	Floating (Don't connected to ground)
7	NC	—	Floating (Don't connected to ground)
8	NC	—	Floating (Don't connected to ground)
9	NC	—	Floating (Don't connected to ground)
10	BT_WAKE	I	HOST wake-up Bluetooth device
11	BT_HOST_WAKE	O	Bluetooth device to wake-up HOST
12	WL_GPIO_5	I/O	WL_GPIO_5
13	WL_GPIO_4	I/O	WL_GPIO_4
14	WL_GPIO_3	I/O	WL_GPIO_3
15	WL_GPIO_2	I/O	WL_GPIO_2
16	WL_GPIO_1	I/O	WL_GPIO_1
17	WL_GPIO_9	I/O	WL_GPIO_9
18	WL_GPIO_8	I/O	WL_GPIO_8
19	WL_GPIO_6	I/O	WL_GPIO_6
20	GND	—	Ground connections
21	GND	—	Ground connections
22	NC	—	Floating (Don't connected to ground)
23	NC	—	Floating (Don't connected to ground)
24	NC	—	Floating (Don't connected to ground)
25	NC	—	Floating (Don't connected to ground)
26	NC	—	Floating (Don't connected to ground)
27	GND	—	Ground connections
28	NC	—	Floating (Don't connected to ground)
29	VDDIO	P	I/O Voltage supply input
30	VDDIO	P	I/O Voltage supply input
31	GND	—	Ground connections
32	NC	—	Floating (Don't connected to ground)
33	GND	—	Ground connections
34	GND	—	Ground connections

35	PCIE_RCLK_P	I	PCI Express differential clock input-Positive
36	PCIE_RCLK_N	I	PCI Express differential clock input-Negative
37	GND	—	Ground connections
38	PCIE_TDP	O	PCI Express transmit data-Negative
39	PCIE_TDN	O	PCI Express transmit data-Positive
40	GND	—	Ground connections
41	PCIE_RDP	I	PCI Express receive data-Positive
42	PCIE_RDN	I	PCI Express receive data-Negative
43	GND	—	Ground connections
44	NC	—	Floating (Don't connected to ground)
45	GND	—	Ground connections
46	PCIE_PREST_L	I	PCIe host indication to reset the device
47	PCIE_CLKREQ_L	OD	PCIe clock request
48	PCIE_PME_L	OD	PCI power management event output
49	GND	—	Ground connections
50	GND	—	Ground connections
51	NC	—	Floating (Don't connected to ground)
52	NC	—	Floating (Don't connected to ground)
53	GND	—	Ground connections
54	VBAT	P	Main power voltage source input
55	VBAT	P	Main power voltage source input
56	GND	—	Ground connections
57	LPO_IN	I	External Low Power Clock input (32.768KHz)
58	GND	—	Ground connections
59	BT_REG_ON	I	Low asserting reset for Bluetooth core
60	WL_REG_ON	I	Low asserting reset for Wi-Fi core
61	WL_HOST_WAKE/WL_GPIO_0	O	WLAN to wake-up HOST and WL_GPIO_0
62	BT_UART_CTS_N	I	Bluetooth UART clear to send
63	BT_UART_TXD	O	Bluetooth UART serial data output
64	BT_UART_RXD	I	Bluetooth UART serial data input
65	BT_UART_RTS_N	O	Bluetooth UART request to send
66	GND	—	Ground connections
67	BT_PCM_CLK	I/O	BT PCM CLK; can be master (output) or slave (input)
68	BT_PCM_IN	I	BT PCM data input
69	BT_PCM_OUT	O	BT PCM data output
70	BT_PCM_SYNC	I/O	BT PCM sync ; can be master (output) or slave (input)
71	GND	—	Ground connections

72	GND	—	Ground connections
73	GND	—	Ground connections
74	GND	—	Ground connections
75	GND	—	Ground connections
76	GND	—	Ground connections
77	GND	—	Ground connections
78	GND	—	Ground connections
79	GND	—	Ground connections
80	GND	—	Ground connections
81	GND	—	Ground connections
82	GND	—	Ground connections
83	GND	—	Ground connections
84	GND	—	Ground connections
85	GND	—	Ground connections
96	GND	—	Ground connections
87	GND	—	Ground connections
88	GND	—	Ground connections
89	GND	—	Ground connections
90	GND	—	Ground connections
91	GND	—	Ground connections
92	GND	—	Ground connections
93	GND	—	Ground connections
94	GND	—	Ground connections
95	GND	—	Ground connections
96	GND	—	Ground connections
G1	GND	—	Ground connections
G2	GND	—	Ground connections
G3	GND	—	Ground connections
G4	GND	—	Ground connections
G5	GND	—	Ground connections
G6	GND	—	Ground connections
G7	GND	—	Ground connections
G8	GND	—	Ground connections
G9	GND	—	Ground connections
G10	GND	—	Ground connections
G11	GND	—	Ground connections
G12	GND	—	Ground connections

7. Dimensions

7.1 Module Dimensions

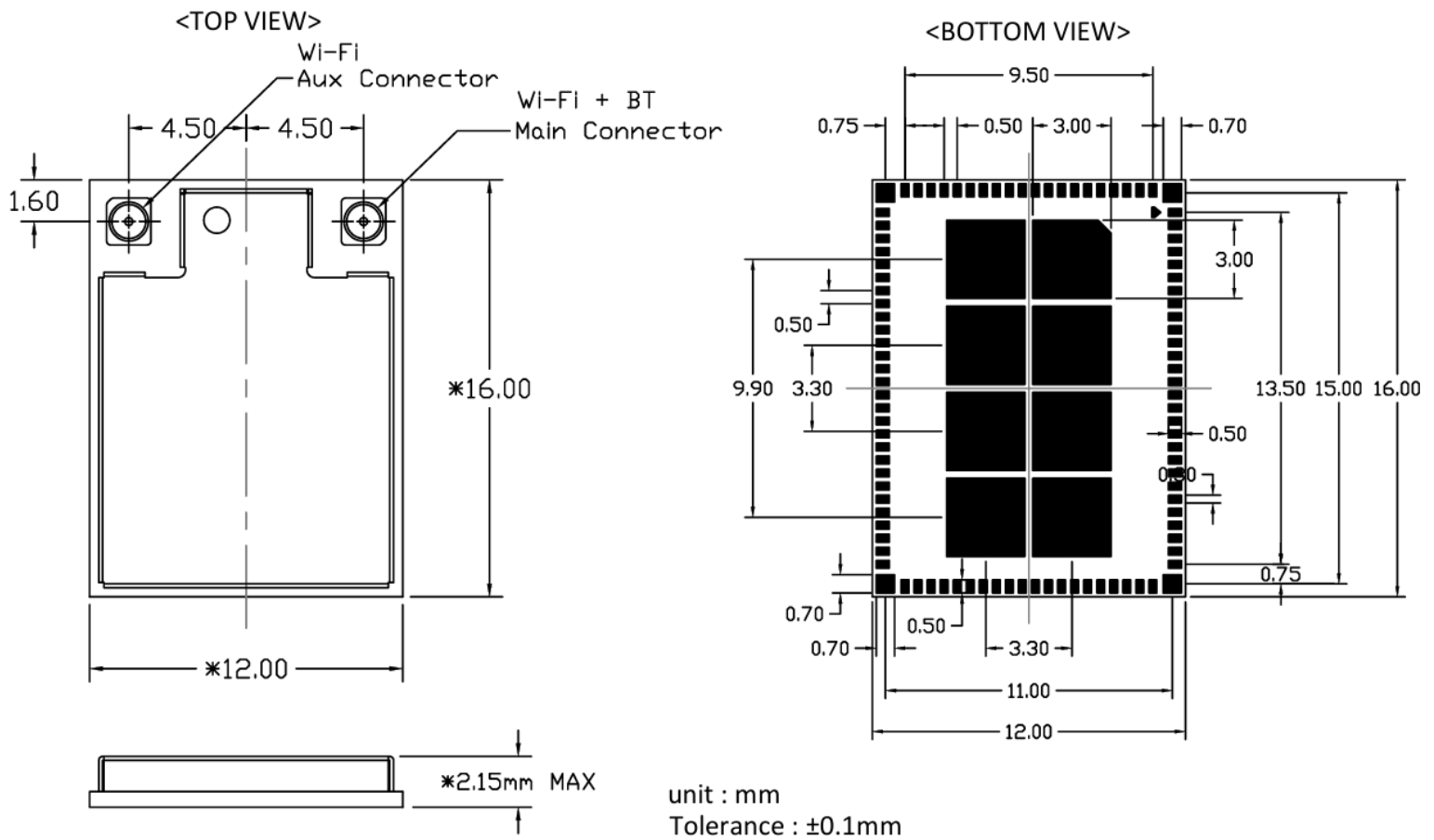

PHYSICAL DIMENSIONS

7.2 Recommended footprint

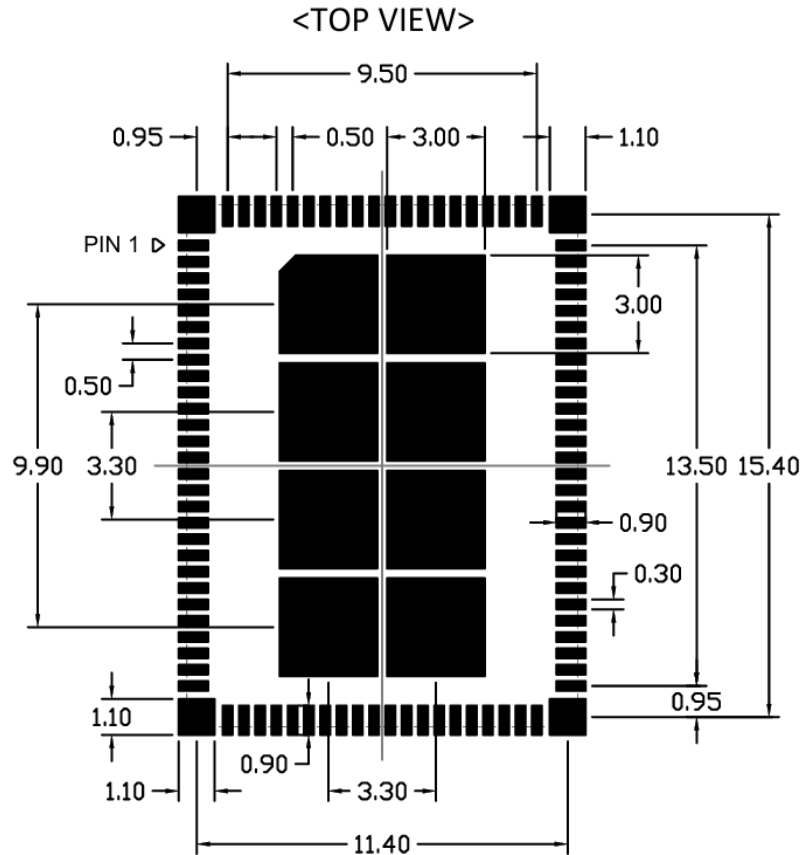

- Solder paste layer design is generally the same as recommended footprint.
(錫膏層設計通常建議和焊墊尺寸相同)
- If soldering quality with good wetting on upright side is essential for PQC, how to optimize the aperture design in the stencil to adjust the amount of solder paste would be crucial. In addition, a kind of stencil design with stepped thickness in partial area would be considered if the thickness of stencil is about 0.1mm or thinner. Please optimize the stencil design by manufacture engineer or contact AMPAK FAE for assistance.
(如果模組吃錫品質考量側面爬錫，如何優化鋼網開孔設計以調整適當的錫膏量是非常重要的。尤其鋼網的厚度大約是 0.1mm 或更薄時，可考慮局部加厚鋼網的設計。請諮詢製程工程師以優化鋼網的設計,或是聯絡正基科技技術支持團隊)。

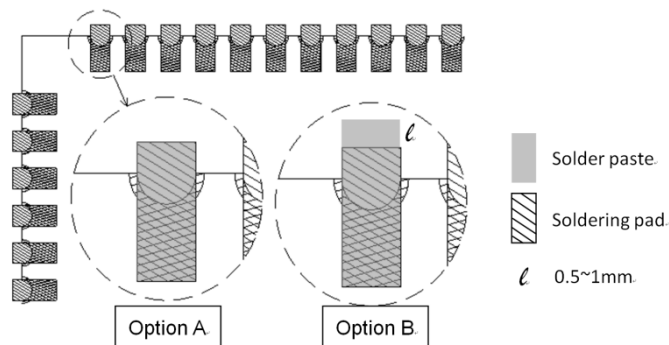

8. External clock reference

External LPO signal characteristics

Parameter	Specification	Units
Nominal input frequency	32.768	kHz
Frequency accuracy	+/-25	ppm
Duty cycle	30 - 70	%
Input signal amplitude	1.8±0.09	V
Signal type	Square-wave or sine-wave	-
Input impedance	>100k	Ω
	<5	pF
Clock jitter (integrated over 300Hz – 15KHz)	<1	Hz
Output high voltage	0.7V _{io} - V _{io}	V

9. Host Interface Timing Diagram

9.1 Power-up Sequence Timing Diagram

The module has signals that allow the host to control power consumption by enabling or disabling the Bluetooth, WLAN and internal regulator blocks. These signals are described below.

Additionally, diagrams are provided to indicate proper sequencing of the signals for various operating states. The timing values indicated are minimum required values; longer delays are also acceptable.

- **WL_REG_ON:** This signal is used by the PMU to power up the WLAN section. It is also OR-gated with the BT_REG_ON input to control the internal regulators. When this pin is high, the regulators are enabled and the WLAN section is out of reset. When this pin is low, the WLAN section is in reset. If BT_REG_ON and WL_REG_ON are both low, the regulators are disabled.
- **BT_REG_ON:** This signal is used by the PMU to decide whether or not to power down the internal regulators. If BT_REG_ON and WL_REG_ON are low, the regulators will be disabled.
- It suggests customers connect WL_REG_ON and BT_REG_ON to GPIOs for control, otherwise unexpected errors may occur when boot-up the device.
- In the figure, The VDDIO power supply has been included in the module. When VBAT is power-up, VDDIO will rise to high level after 15 ms.
- The module main chip has an internal power-on reset (POR) circuit. The device will be held in reset for a maximum of 110 ms after VDDC and VDDIO have both passed the POR threshold. Wait at least 150 ms after VDDC and VDDIO are available before initiating PCIe accesses.

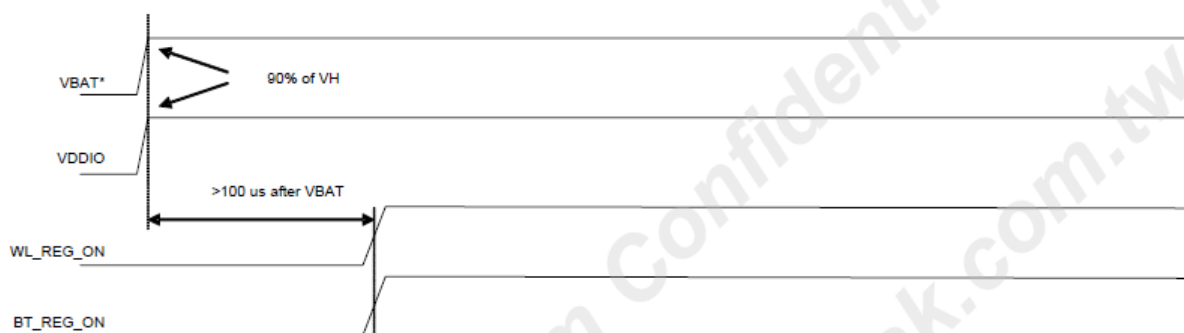

***Notes:**

1. The VBAT and VDDIO 10%–90% rise-time slopes must be greater than 50 microseconds/V.
2. VBAT should be up before or at the same time as VDDIO. VDDIO should NOT be present first or be held high before VBAT is high.

WLAN=ON, Bluetooth=ON

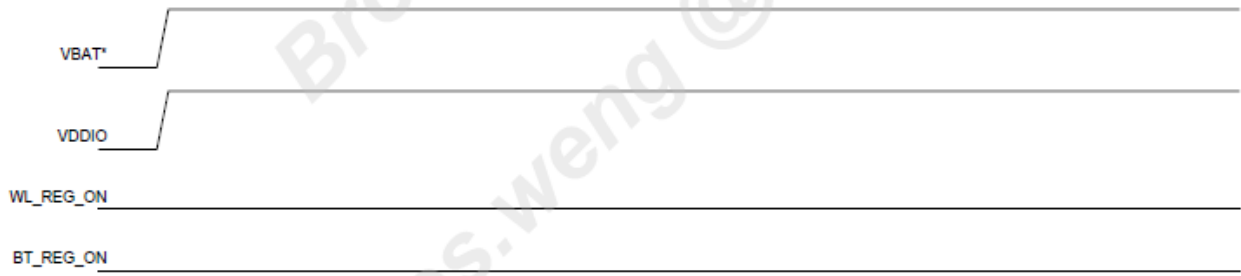

***Notes:**

1. The VBAT and VDDIO 10%–90% rise-time slopes must be greater than 50 microseconds/V.
2. VBAT should be up before or at the same time as VDDIO. VDDIO should NOT be present first or be held high before VBAT is high.

WLAN=OFF, Bluetooth=OFF

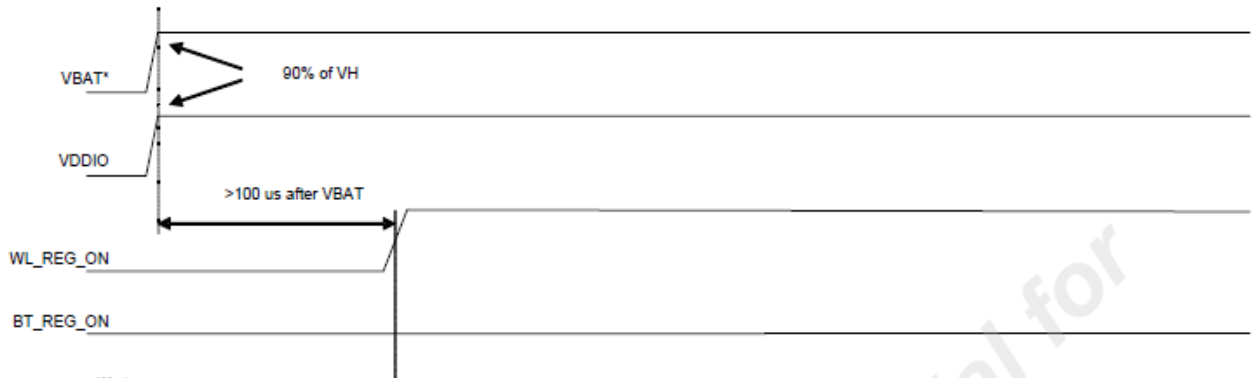

***Notes:**

1. The VBAT and VDDIO 10%–90% rise-time slopes must be greater than 50 microseconds/V.
2. VBAT should be up before or at the same time as VDDIO. VDDIO should NOT be present first or be held high before VBAT is high.

WLAN=ON, Bluetooth=OFF

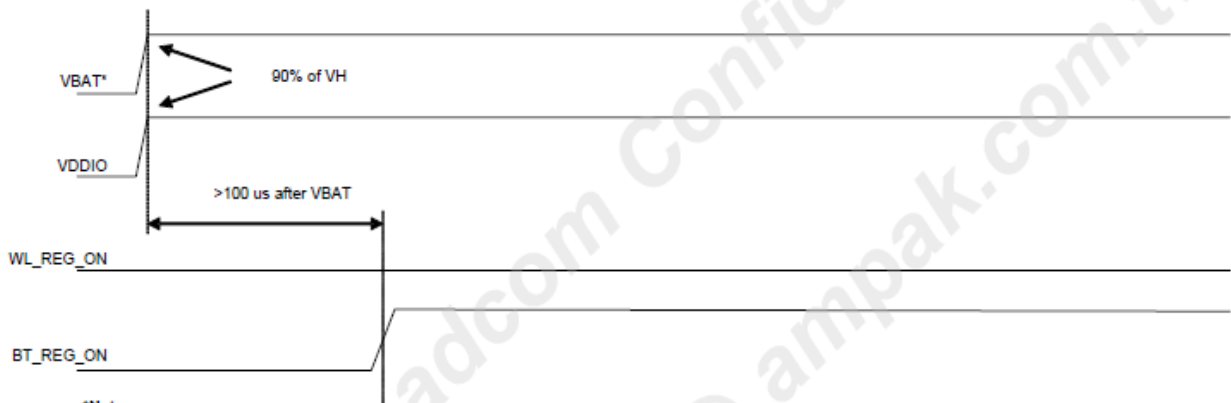

***Notes:**

1. The VBAT and VDDIO 10%–90% rise-time slopes must be greater than 50 microseconds/V.
2. VBAT should be up before or at the same time as VDDIO. VDDIO should NOT be present first or be held high before VBAT is high.

WLAN=OFF, Bluetooth=ON



9.2 PCIe Interface Description

The PCI Express(PCIe) core on the AP6684SDPR is a high-performance serial I/O interconnect that is protocol compliant and electrically compatible with the PCI Express Base Specification v3.0 running at Gen2 speeds.

Parameter	Symbol	Comments	Minimum	Typical	Maximum	Unit
General¹						
Baud rate	BPS	–	–	5	–	Gbaud
Reference clock peak-to-peak differential ²	Vref	LVPECL, AC coupled	0.95	–	–	V
Receiver						
Differential termination	ZRX-DIFF-DC	Differential termination	80	100	120	Ω
DC impedance	ZRX-DC	DC common-mode impedance	40	50	60	Ω
Powered down termination (POS)	ZRX-HIGH-IMP-DC-POS	Power-down or RESET high impedance	100k	–	–	Ω
Powered down termination (NEG)	ZRX-HIGH-IMP-DC-NEG	Power-down or RESET high impedance	1k	–	–	Ω
Input voltage	VRX-DIFFp-p	AC coupled, differential p-p	175	–	–	mV
Jitter tolerance	TRX-EYE	Minimum receiver eye width	0.4	–	–	UI
Differential return loss	RLRX-DIFF	Differential return loss	10	–	–	dB
Common-mode returnloss	RLRX-CM	Common-mode return loss	6	–	–	dB
Unexpected electrical idle enter detect threshold integration time	TRX-IDEL-DET-DIFF-ENTERTIME	An unexpected electrical idle must be recognized no longer than this time to signal an unexpected idle condition.	–	–	10	ms
Signal detect threshold	VRX-IDLE-DET-DIFFp-p	Electrical idle detect threshold	65	–	175	mV

Transmitter						
Parameter	Symbol	Comments	Minimum	Typical	Maximum	Unit
Output voltage	VTX-DIFFp-p	Differential p-p, programmable in 16 steps	0.8	—	1200	mV
RX detection voltage swing	VTX-RCV-DETECT	The amount of voltage change allowed during receiver detection.	—	—	600	mV
TX AC peak common-mode voltage (2.5 GT/s)	VTX-CM-AC-P	TX AC common-mode voltage (2.5 GT/s)	—	—	20	mV
Absolute delta of DC common-mode voltage during LO and electrical idle	VTX-CM-DC-ACTIVE-IDLE-DELTA	Absolute delta of DC common-mode voltage during LO and electrical idle.	0	—	100	mV
Absolute delta of DC common-mode voltage between D+ and D-	VTX-CM-DC-LINE-DELTA	DC offset between D+ and D-	0	—	25	mV
Electrical idle differential peak output voltage	VTX-IDLE-DIFF-AC-p	Peak-to-peak voltage	0	—	20	mV
TX short circuit current	ITX-SHORT	Current limit when TX output is shorted to ground.	—	—	90	mA
DC differential TX termination	ZTX-DIFF-DC	Low impedance defined during signaling (parameter is captured for 5.0 GHz by RLTX-DIFF)	80	—	120	Ω
Differential return loss	RLTX-DIFF	Differential return loss	10 (min) for 0.05: 1.25 GHz	—	—	dB
Common-mode return loss	RLTX-CM	Common-mode return loss	6	—	—	dB
TX eye width	TTX-EYE	Minimum TX eye width	0.75	—	—	UI

The reference clock inputs comply with the requirements of the PCI Express CEM v2.0 Specification.

PCIe Power-On Timing

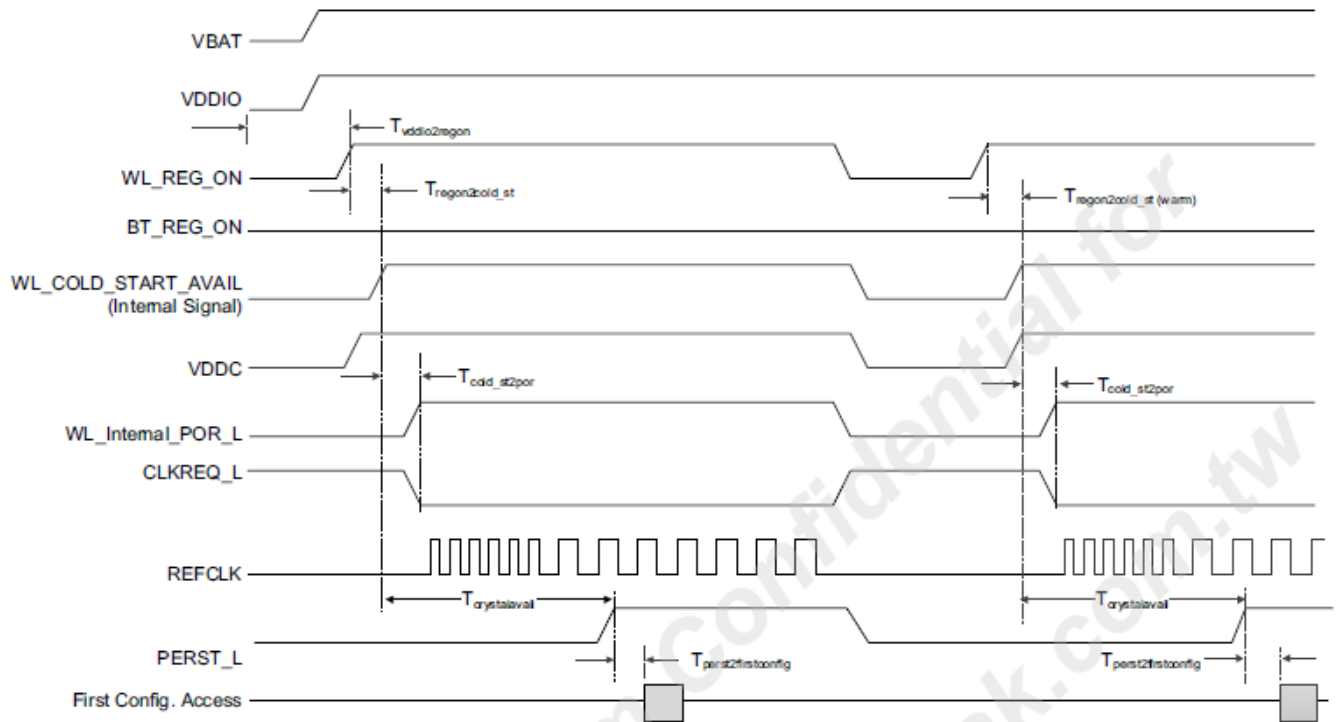

Timing Parameter	Notes	Value ^a	Unit
$T_{vddio2regon}$	–	0.1	ms
$T_{regon2cold_st}$	3.4 ms + 162 instruction-level parallelism (ILP) cycles	10.13	ms
T_{cold_st2por}	54 ILP cycles	2.24	ms
$T_{crystalavail}$	509 ILP cycles	21.17	ms
$T_{perst2firstconfig}$	–	6.0	ms
$T_{vddioon2firstconfig}$	$T_{vddio2regon} + T_{regon2cold_st} + T_{crystalavail} + T_{perst2firstconfig}$	37.4 ^b	ms
$T_{regon2cold_st (warm)}$	162 ILP cycles	6.73	ms

a. The time values assume an ILP tolerance of $\pm 30\%$.

b. With VDDIO as a reference, 37.4 ms is the minimum system wait time before issuing the first configuration access.

9.3 PCM Interface Description

The PCM Interface on the AP6684SDPR can connect to linear PCM Codec devices in master or slave mode. In master mode, the AP6684SDPR generates the PCM_CLK and PCM_SYNC signals, and in slave mode, these signals are provided by another master on the PCM interface and are inputs to the AP6684SDPR. The configuration of the PCM interface may be adjusted by the host through the use of vendor-specific HCI commands.

PCM Timing

Short Frame Sync, Master Mode

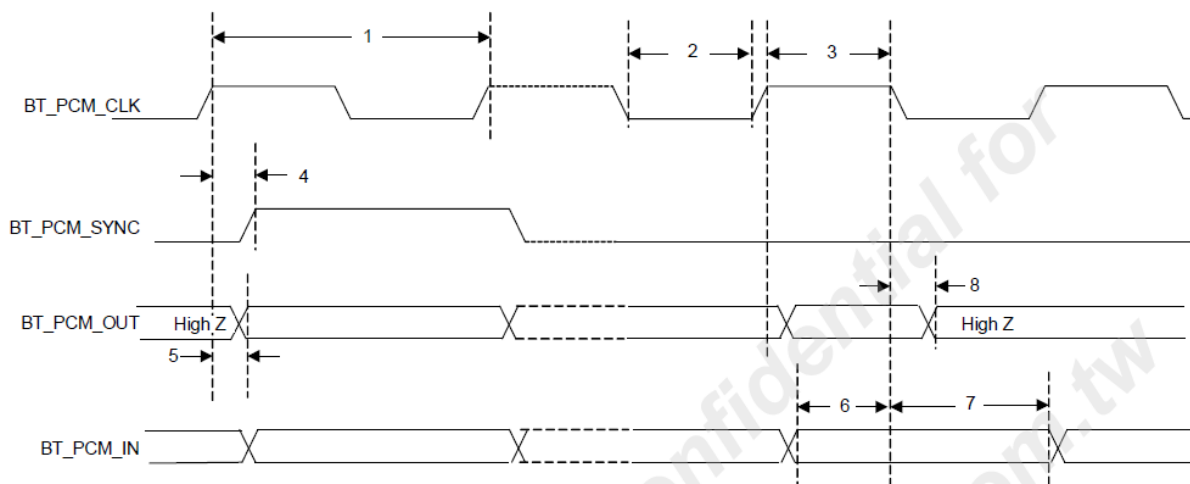

PCM interfce timing spec(short frame sync, master mode)

Reference	Characteristics	Minimum	Typical	Maximum	Unit
1	PCM bit clock frequency	—	—	12	MHz
2	PCM bit clock low	41	—	—	ns
3	PCM bit clock high	41	—	—	ns
4	BT_PCM_SYNC delay	0	—	25	ns
5	BT_PCM_OUT delay	0	—	25	ns
6	BT_PCM_IN setup	8	—	—	ns
7	BT_PCM_IN hold	8	—	—	ns
8	Delay from falling edge of BT_PCM_CLK during the last bit period to BT_PCM_OUT becoming high impedance.	0	—	25	ns

Short Frame Sync, Slave Mode

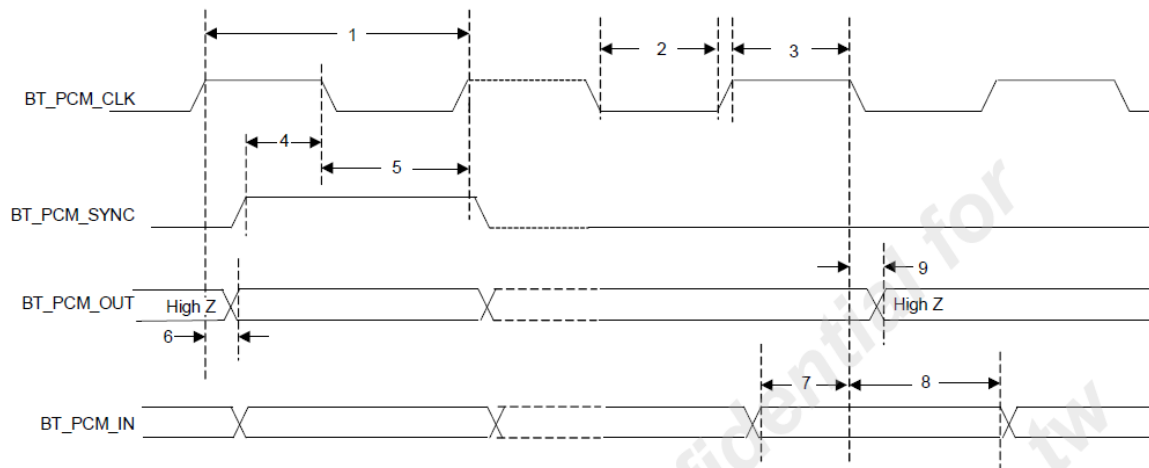

PCM interface timing spec (short frame sync, slave mode)

Reference	Characteristics	Minimum	Typical	Maximum	Unit
1	PCM bit clock frequency	—	—	12	MHz
2	PCM bit clock low	41	—	—	ns
3	PCM bit clock high	41	—	—	ns
4	BT_PCM_SYNC setup	8	—	—	ns
5	BT_PCM_SYNC hold	8	—	—	ns
6	BT_PCM_OUT delay	0	—	25	ns
7	BT_PCM_IN setup	8	—	—	ns
8	BT_PCM_IN hold	8	—	—	ns
9	Delay from falling edge of BT_PCM_CLK during the last bit period to BT_PCM_OUT becoming high impedance.	0	—	25	ns

Long Frame Sync, Master Mode

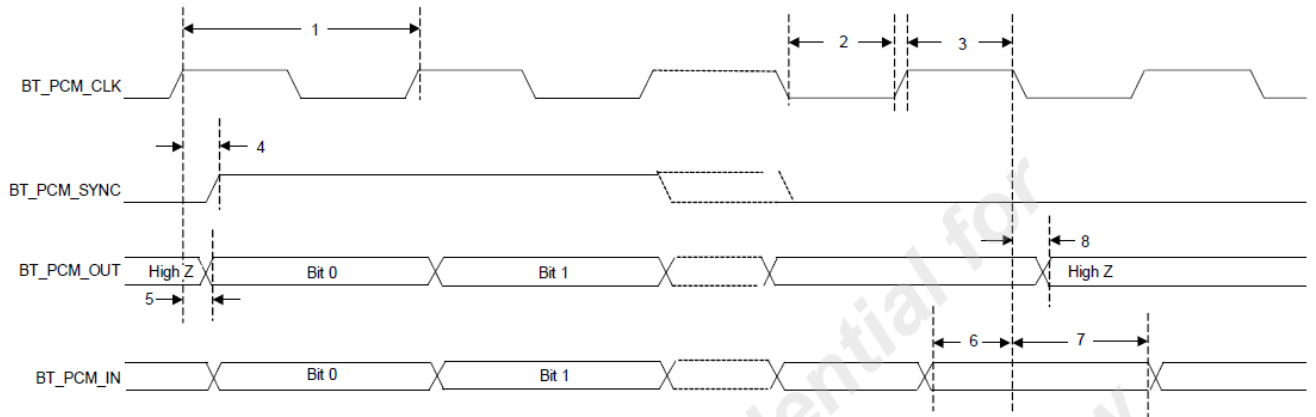

PCM interface timing spec (long frame sync, master mode)

Reference	Characteristics	Minimum	Typical	Maximum	Unit
1	PCM bit clock frequency	—	—	12	MHz
2	PCM bit clock low	41	—	—	ns
3	PCM bit clock high	41	—	—	ns
4	BT_PCM_SYNC delay	0	—	25	ns
5	BT_PCM_OUT delay	0	—	25	ns
6	BT_PCM_IN setup	8	—	—	ns
7	BT_PCM_IN hold	8	—	—	ns
8	Delay from falling edge of BT_PCM_CLK during the last bit period to BT_PCM_OUT becoming high impedance.	0	—	25	ns



Long Frame Sync, Slave Mode

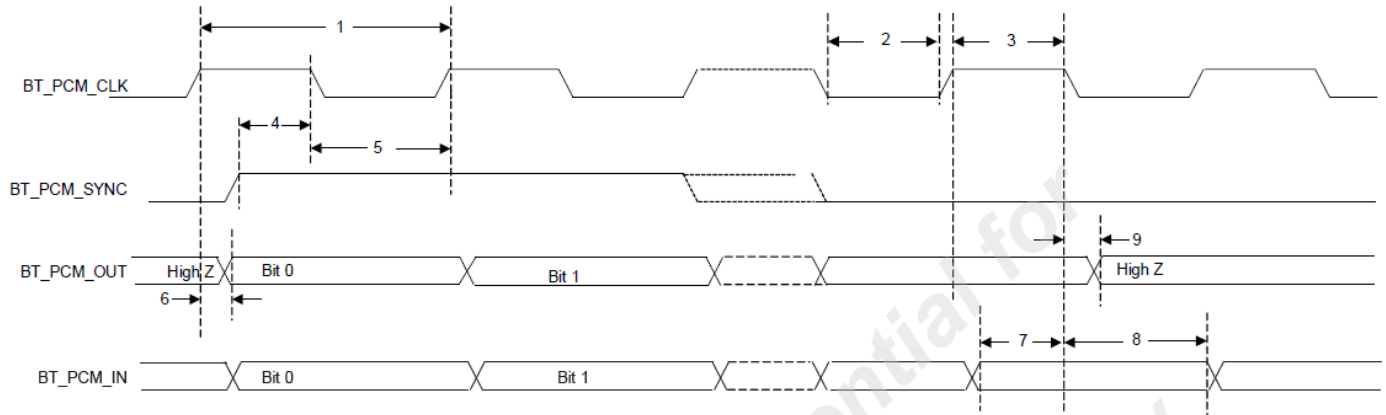

PCM interface timing spec (long frame sync, slave mode)

Reference	Characteristics	Minimum	Typical	Maximum	Unit
1	PCM bit clock frequency	—	—	12	MHz
2	PCM bit clock low	41	—	—	ns
3	PCM bit clock high	41	—	—	ns
4	BT_PCM_SYNC setup	8	—	—	ns
5	BT_PCM_SYNC hold	8	—	—	ns
6	BT_PCM_OUT delay	0	—	25	ns
7	BT_PCM_IN setup	8	—	—	ns
8	BT_PCM_IN hold	8	—	—	ns
9	Delay from falling edge of BT_PCM_CLK during the last bit period to BT_PCM_OUT becoming high impedance.	0	—	25	ns

Short Frame Sync, Burst Mod

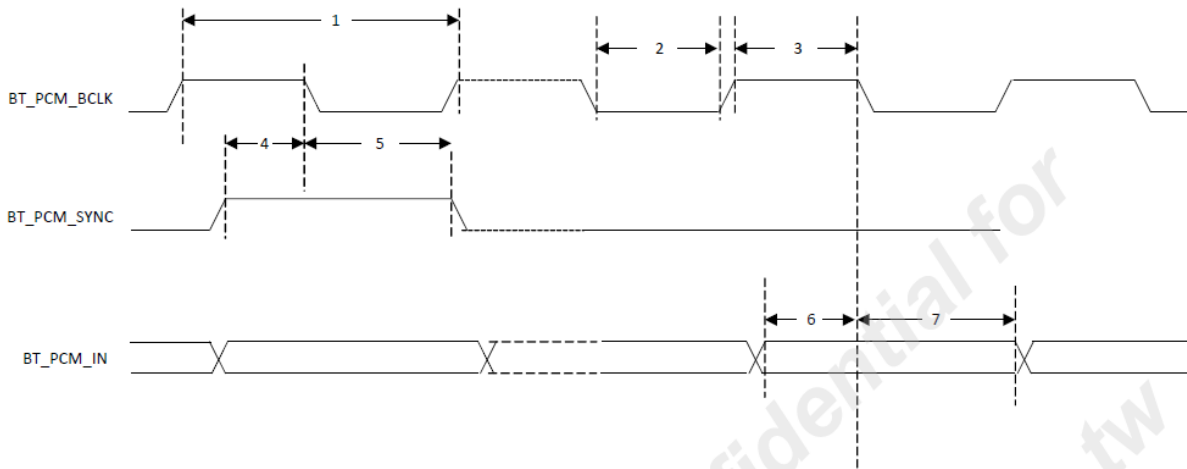

PCM burst mode (receive only, short frame sync)

Reference	Characteristics	Minimum	Typical	Maximum	Unit
1	PCM bit clock frequency	—	—	24	MHz
2	PCM bit clock low	20.8	—	—	ns
3	PCM bit clock high	20.8	—	—	ns
4	BT_PCM_SYNC setup	8	—	—	ns
5	BT_PCM_SYNC hold	8	—	—	ns
6	BT_PCM_IN setup	8	—	—	ns
7	BT_PCM_IN hold	8	—	—	ns

Long Frame Sync, Burst Mode

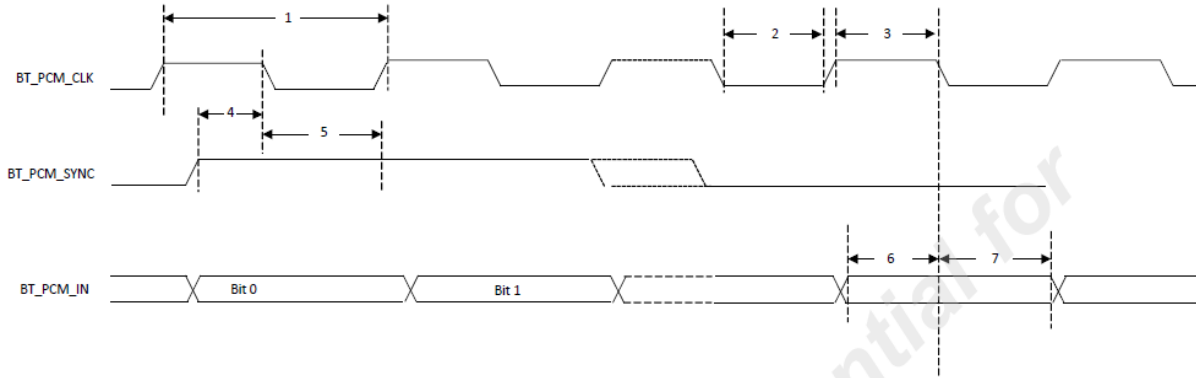

PCM burst mode (receive only, long frames sync)

Reference	Characteristics	Minimum	Typical	Maximum	Unit
1	PCM bit clock frequency	—	—	24	MHz
2	PCM bit clock low	20.8	—	—	ns
3	PCM bit clock high	20.8	—	—	ns
4	BT_PCM_SYNC setup	8	—	—	ns
5	BT_PCM_SYNC hold	8	—	—	ns
6	BT_PCM_IN setup	8	—	—	ns
7	BT_PCM_IN hold	8	—	—	ns

9.4 UART Interface Description

The UART is a standard 4-wire interface (RX, TX, RTS, and CTS) with adjustable baud rates from 9600 bps to 4.0 Mbps. The interface features an automatic baud rate detection capability that returns a baud rate selection. Alternatively, the baud rate may be selected through a vendor-specific UART HCI command.

UART has a 1040-byte receive FIFO and a 1040-byte transmit FIFO to support EDR. Access to the FIFOs is conducted through the AHB interface through either DMA or the CPU. The UART supports the Bluetooth UART HCI specification: H4, a custom Extended H4, and H5. The default baud rate is 115.2 Kbaud.

The UART supports the 3-wire H5 UART transport, as described in the Bluetooth specification (Three-wire UART Transport Layer). Compared to H4, the H5 UART transport reduces the number of signal lines required by eliminating the CTS and RTS signals.

The UART can perform XON/XOFF flow control and includes hardware support for the Serial Line Input Protocol (SLIP). It can also perform wake-on activity. For example, activity on the RX or CTS inputs can wake the chip from a sleep state.

Normally, the UART baud rate is set by a configuration record downloaded after device reset, or by automatic baud rate detection, and the host does not need to adjust the baud rate. Support for changing the baud rate during normal HCI UART operation is included through a vendor-specific command that allows the host to adjust the contents of the baud rate registers. The UARTs operate correctly with the host UART as long as the combined baud rate error of the two devices is within $\pm 2\%$.

Example of Common Baud Rates

Desired Rate	Actual Rate	Error (%)
4000000	4000000	0.00
3692000	3692308	0.01
3000000	3000000	0.00
2000000	2000000	0.00
1500000	1500000	0.00
1444444	1454544	0.70
921600	923077	0.16
460800	461538	0.16
230400	230796	0.17
115200	115385	0.16
57600	57692	0.16
38400	38400	0.00
28800	28846	0.16
19200	19200	0.00
14400	14423	0.16
9600	9600	0.00

UART Timing

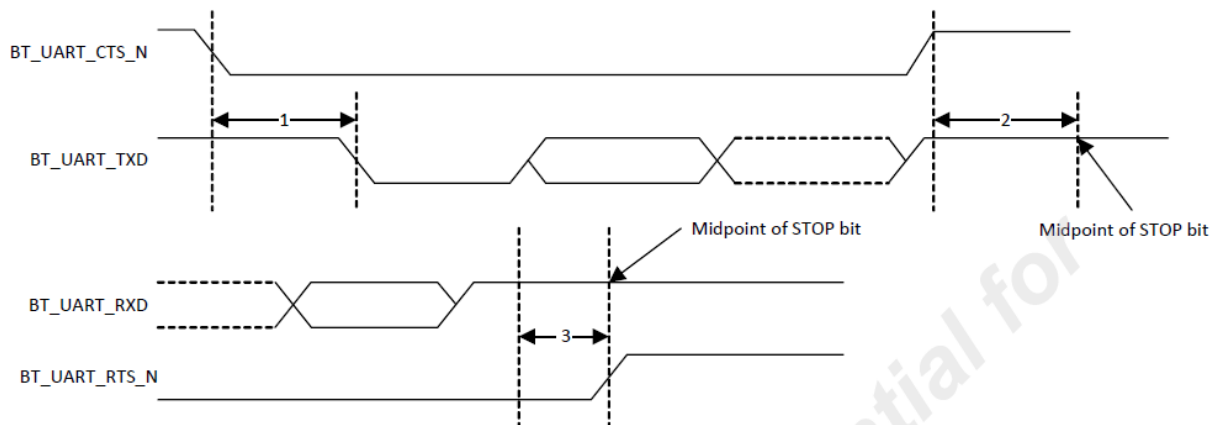

Reference	Characteristics	Minimum	Typical	Maximum	Unit
1	Delay time, BT_UART_CTS_N low to BT_UART_TXD valid	—	—	1.5	Bit periods
2	Setup time, BT_UART_CTS_N high before midpoint of stop bit	—	—	0.5	Bit periods
3	Delay time, midpoint of stop bit to BT_UART_RTS_N high	—	—	0.5	Bit periods



10. Recommended Reflow Profile

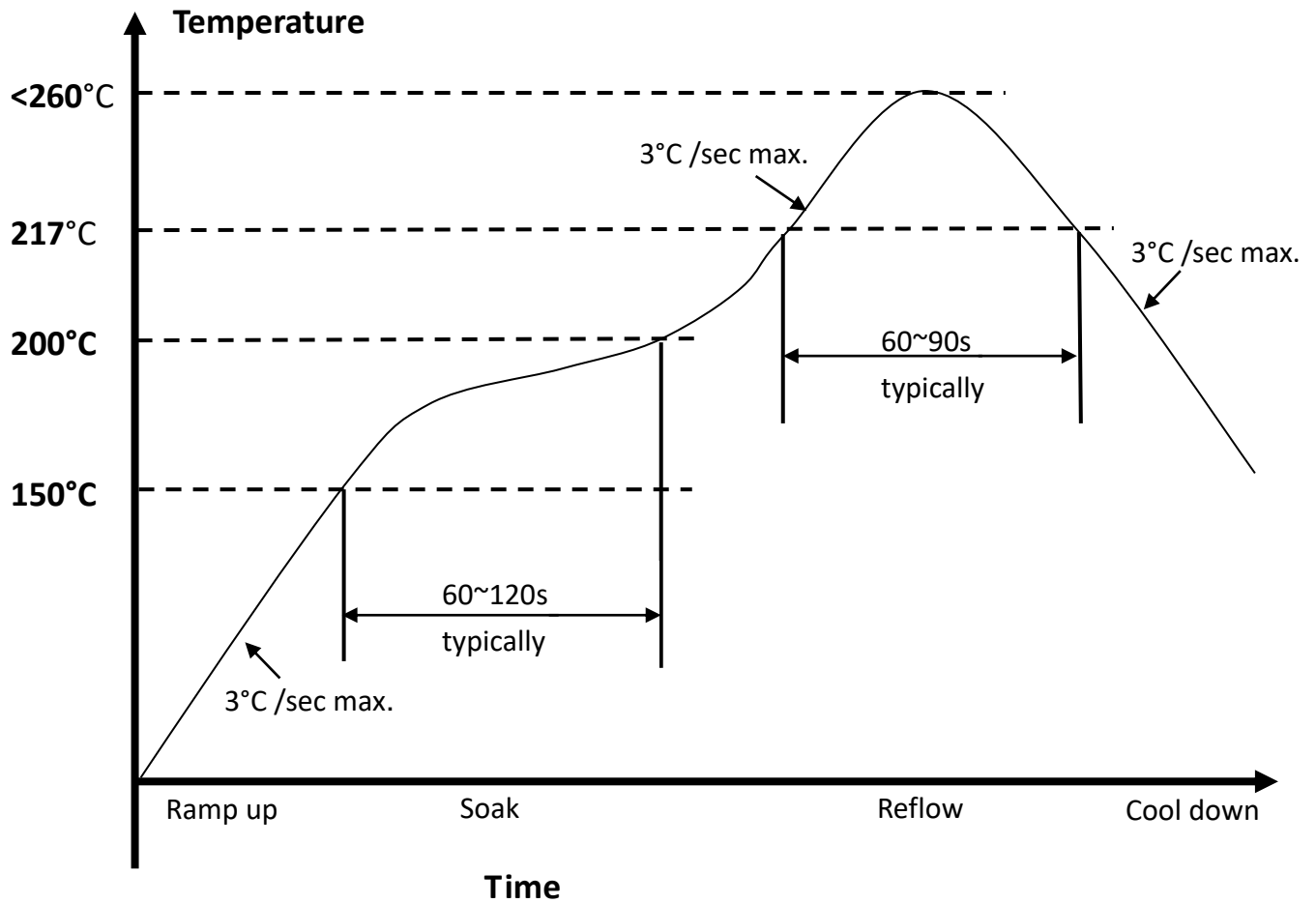

1. Referred to IPC/JEDEC standard
2. Peak Temperature : $<260^{\circ}\text{C}</math> (Time within 5°C of actual Peak Temperature 20-40 seconds)$
3. Cycle of Reflow : 2 times max.
4. Adding Nitrogen (N_2) to implement 2000ppm or less of oxygen concentration during reflow process is recommended.
5. If the shelf time is exceeded, be sure baking step to remove the moisture from the component

11. Package Information

11.1 Marking

Rows	Content	Note
Row 1	XXXXXXXX	Model Name
Row 2	XXXXXXXX or XXXXXXXX (8 digitals or 9 digitals)	Lot Code
Row 3	YYWW	Date Code
Row 4	Through hole or non through hole	Pin 1 indicator

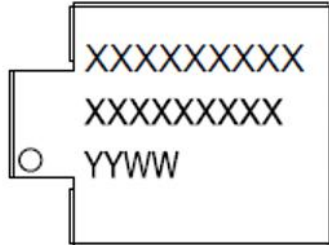

11.2 Tape & Reel Date



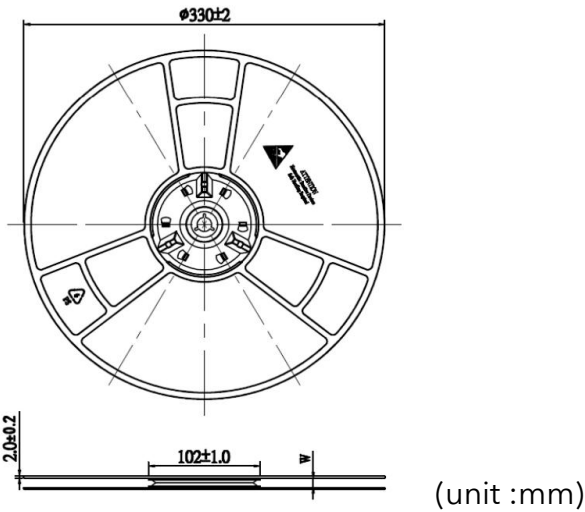

Reel

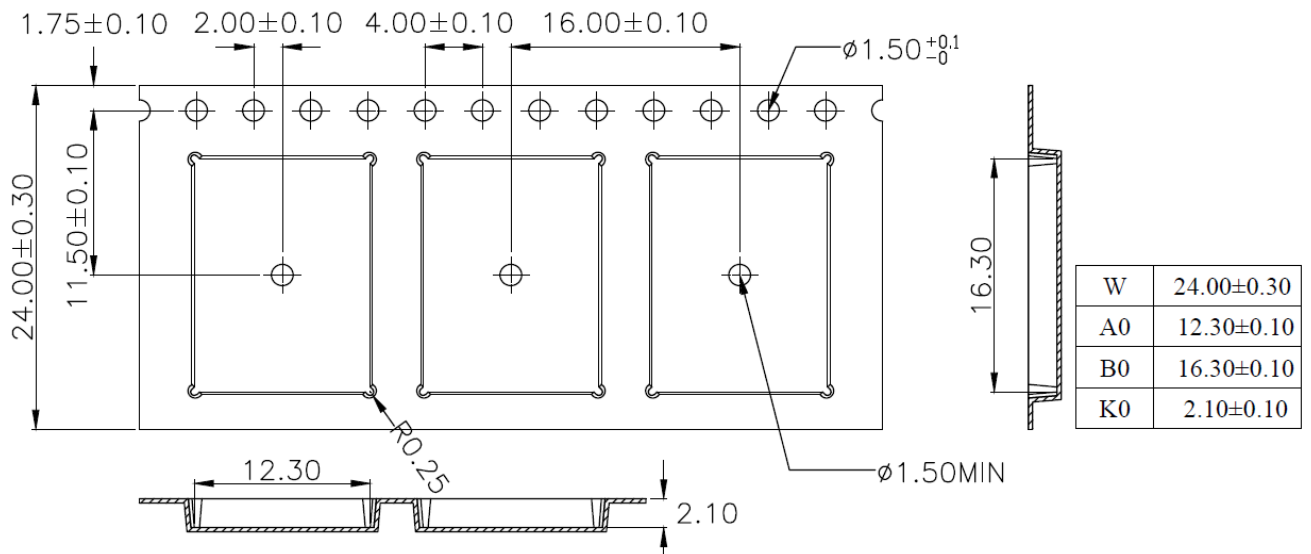

Carrier tape

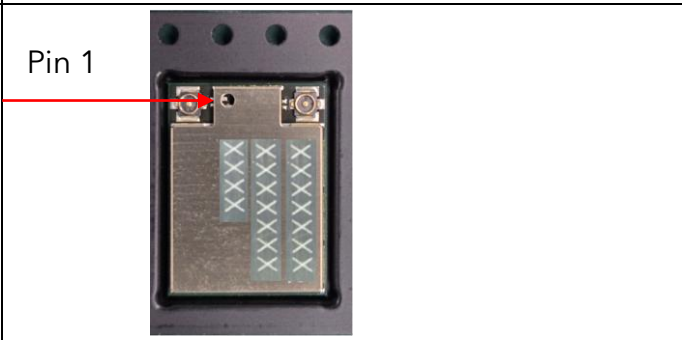

11.3 Tape & Reel Packing

Items	Photo	Description
1		Pin 1 indicator in carrier tape
2		13" W24.0mm Reel
3		Humidity Indicator Card & Desiccant inside
4		MSL Caution label on top side of Al bag
5		Anti-static and humidity notice on top side of Al bag

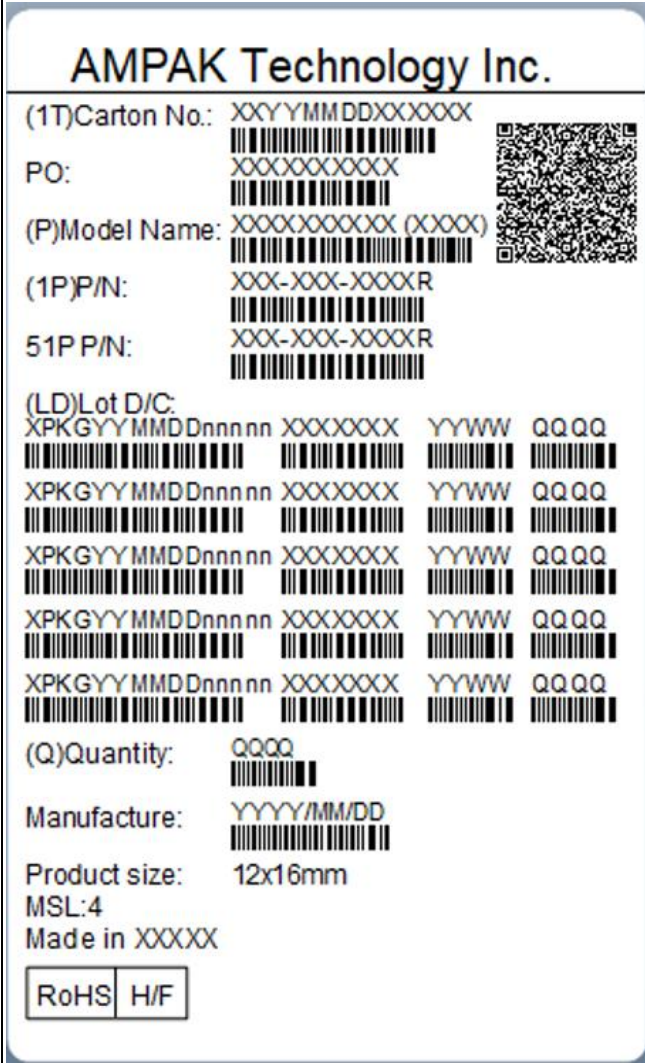

<p>10</p>		<p>Outer box (Carton)</p> <p>Quantity: 5000pcs/outer box (Carton)</p>
<p>11</p>	 <p>AMPAK Technology Inc.</p> <p>(1T)Carton No.: XXXYYMMDDXXXXXX PO: XXXXXXXXXX (P)Model Name: XXXXXXXXXX (XXXX) (1P)P/N: XXX-XXX-XXXXR 51P P/N: XXX-XXX-XXXXR</p> <p>(LD)Lot D/C: XPKGY YMMDDnnn nn XXXXXXX YYWW QQQQ XPKGY YMMDDnnn nn XXXXXXX YYWW QQQQ XPKGY YMMDDnnn nn XXXXXXX YYWW QQQQ XPKGY YMMDDnnn nn XXXXXXX YYWW QQQQ XPKGY YMMDDnnn nn XXXXXXX YYWW QQQQ</p> <p>(Q)Quantity: QQQQ Manufacture: YYYY/MM/DD Product size: 12x16mm MSL:4 Made in XXXXX</p> <p>RoHS H/F</p>	<p>Outer box (Carton) label</p> <p>The label content includes barcode and QR CODE</p>